

**INSTITUTE WORKS DEPARTMENT
INDIAN INSTITUTE OF TECHNOLOGY ROORKEE**

E-TENDER DOCUMENT

For

“Supply, Installation, Testing and Commissioning of 13 Passenger and service (Goods cum Passenger) MRL Lifts with 8 stops for G+7 Building in the existing shaft including dismantling, removal and buyback of existing lift with accessories at Hill View Apartment & RK Bhawan at IIT Roorkee”



**Indian Institute of Technology Roorkee
Roorkee-247667, Tel.no. 01332-28-5747/5386**

TABLE OF CONTENTS

Section	Subject	Page No.
1	Notice inviting tender (invitation for bids)	3-5
2	Instructions for online bid submission	6-7
3	Information and instructions for bidders	8-10
4	General instructions (A to G)	11-15
5	Qualifying Information	16-17
6	General conditions of contract (A to E)	18-30
7	Special conditions of contract	31-34
8	Undertaking	35
9	Performance guarantee bond	36
10	Annexure-I	37
11	Annexure-II	38
12	Annexure-B (Site conditions)	39
13	Technical Specifications	40-48
14	CAMC Scope of Work	49
15	Schedule of Quantities	50-51

**INSTITUTE WORKS DEPARTMENT
INDIAN INSTITUTE OF TECHNOLOGY ROORKEE**

No. IWD/DI/etender/Lift/Re2/105

Dated: 26.10.2024

NOTICE INVITING TENDER

On behalf of BOG, I.I.T. Roorkee, online Tenders (Percentage Rate) are invited in two Bid systems (Technical and Financial) from eligible bidders of appropriate class & category registered with CPWD, State PWD, MES, having experience of working in Central / State Government, Public Sector Undertaking / Autonomous Organization of Central / State Government and Working Contractors of IITR who fulfil the PQ criteria for the following work:

Name of the Work	Estimated Cost	Completion Period (Months)
“Supply, Installation, Testing and Commissioning of 13 Passenger and service (Goods cum Passenger) MRL Lifts with 8 stops for G+7 Building in the existing shaft including dismantling, removal and buyback of existing lift with accessories at Hill View Apartment & RK Bhawan at IIT Roorkee”	Rs. 442.52 Lacs (inclusive of GST & Cess).	07 Months

- Interested eligible Bidders may obtain further information from IIT Roorkee website: www.iitr.ac.in (<http://mm.iitr.ac.in/mmweb/tenders>) or from Central Public Procurement Portal (CPPP) <https://eprocure.gov.in/eprocure/app>.
- Intending bidders are advised to visit IIT Roorkee website www.iitr.ac.in (<http://mm.iitr.ac.in/mmweb/tenders>) and Central Public Procurement Portal (CPPP) <https://eprocure.gov.in/eprocure/app> regularly till closing date of BID submission of tender for any corrigendum / addendum/ amendment.

Critical Data Sheet

Sr. No.	Name of Organization	Indian Institute of Technology Roorkee
1	Tender Type (Open/Limited/EOI/Auction/Single)	Open
2	Tender Category (Services/Goods/Works)	Works
3	Type/Form of Contract (Work/Supply/ Auction/ Service/ Buy/ Empanelment/ Sell)	Work Contract
4	Product Category (Civil Works/Electrical Works / Fleet Management / Computer Systems)	Electrical Works
5	Date of Issue/Publishing Original Tender	26.10.2024 (17:30 Hrs.)
6	Document Download / Sale Start Date	26.10.2024 (17:30 Hrs.)
7	Pre-bid Meeting	NA
8	Seek Clarification Start Date	26.10.2024 (17:30 Hrs.)
9	Seek Clarification End Date	01.11.2024 (12:30 Hrs.)
10	Bid Submission Start Date	07.11.2024 (12:30 Hrs.)
11	Bid Submission Closing Date	15.11.2024 (12:30 Hrs.)
12	Bid Opening Date	16.11.2024 (12:30 Hrs.)
13	Tender Fee	Rs.1000.00+18% GST (non-refundable). Payment of the Tender Fee can be made by RTGS, NEFT in below mentioned account no. 1. Account Name- NON-MHRD GOVERNMENT FUND IIT ROORKEE 2. Address- IIT Roorkee, Haridwar. a. Account No.- 0000032685865515 4. Account Description- Regular SB Chq-Entities.

		5. Branch- IIT Roorkee , 6. CIF No- 86531323246 7. IFS Code. - SBIN0001069 , 8. MICR Code. - 247002094
14	EMD (2%)	Rs. 8,86,000/- Payment of EMD can be made by RTGS, NEFT in below mentioned account no. The bidders shall be required to upload the scanned copies of transaction of payment of tender EMD / Tender Fee including e-receipt (clearly indicating UTR No. & Tender Reference i.e. NIT No. must be entered in the remark at the time of online transaction of payment, failing which payment may not be considered) at the time of online bid submission on e-tendering website. Tender fee /EMD may be submitted online as per details given below. 1. Account Name- NON MHRD GOVERNMENT FUND IIT ROORKEE 2. Address- IIT Roorkee, Haridwar. a. Account No.- 00000032685865515 4. Account Description- Regular SB Chq-Entities. 5. Branch- IIT Roorkee , 6. CIF No- 86531323246 7. IFS Code. - SBIN0001069 , 8. MICR Code. - 247002094
15	Performance Guarantee (5%)	5% of awarded value (Part-A) shall be submitted in the form of Bankers Cheque / DD / FDR / Bank Guarantee in the name of Institute Engineer, IIT Roorkee after issue of Letter of Acceptance (LOA).
16	Security Deposit (5%)	5% of awarded value (Part-A) shall be submitted in the form of Bankers Cheque / DD/FDR / Bank Guarantee in the name of Institute Engineer, IIT Roorkee after issue of Letter of Acceptance (LOA).
17	No. of Covers (1/2/3/4)	02 (Cover-1 for Technical+ Cover-2 for Financial)
18	Bid Validity Days (180/120/90/60/30)	90 days (from last date of opening of financial bid)
19	Documents to be uploaded on CPP Portal (http://eprocure.gov.in/eprocure/app)(related to eligibility criteria) on or before due date of submission of tender.	1) Affidavit (on Rs.10 non-judicial stamp with notarized) regarding establishment of proprietorship firm / partnership deed / letter of incorporation for private ltd / ltd firm with written power of attorney (in case of bidder is owner, not required) of the authorized signatory. 2) Self-certified copy of work orders along with work completion certificate as per eligibility criteria. Proof of online deposit of tender fee and EMD. 3) Solvency certificate as per the tender document and Annexure-I & Annexure-II. 4) Turnover certificate from CA preferably with UDIN Number, GST registration certificate, PAN Card, ESI registration certificate & EPF registration certificate. 5) Qualifying information (Annexure-A) & Notarized undertaking on Rs. 100 non-judicial stamp paper as per the NIT, Valid Electrical Contractor License Class-A. 6) Authorization certificate from OEM of lift mentioning full back support including spares during the useful life of the lifts. The OEM should

		<p>have an established service center operational since last 3 years within 75 km road distance from IIT Roorkee (main campus) at the time of submission of bid. Attach proof such as rent agreement / shop registration etc.</p> <p>7) Filled Annexure-C (signed by bidder & OEM) and Annexure-D (signed by bidder & OEM).</p>
20	Price Bid	<p>To be uploaded only on CPP Portal (http://eprocure.gov.in/eprocure/app) in excel sheet.</p>
21	Address for communication	<p>Executive Engineer (E/M), Institute Works Department, James Thomson Building, IIT Roorkee, Roorkee-247667 (India), Tel. No. 01332-285747 / 5386</p>
22	Email Address	<p>ee-electrical@iitr.ac.in / neeraj.aee2018@iitr.ac.in</p>

**Sd-
Institute Engineer,
IWD, IIT Roorkee**

INSTRUCTIONS FOR ONLINE BID SUBMISSION

As per the directives of Department of Expenditure, this tender document has been published on the Central Public Procurement Portal (URL: <https://eprocure.gov.in/eprocure/app>). The bidders are required to submit soft copies of their bids electronically on the CPP Portal, using valid Digital Signature Certificates. The instructions given below are meant to assist the bidders in registering on the CPP Portal, prepare their bids in accordance with the requirements and submitting their bids online on the CPP Portal. More information useful for submitting online bids on the CPP Portal may be obtained at: <https://eprocure.gov.in/eprocure/app> .

1.0 Registration

- 1.1 Bidders are required to enroll on the e-Procurement module of the Central Public Procurement Portal (URL: <https://eprocure.gov.in/eprocure/app>) by clicking on the link “Click here to Enroll”. Enrolment on the CPP Portal is free of charge.
- 1.2 As part of the enrolment process, the bidders will be required to choose a unique username and assign a password for their accounts.
- 1.3 Bidders are advised to register their valid email address and mobile numbers as part of the registration process. These would be used for any communication from the CPP Portal.
- 1.4 Upon enrolment, **the bidders will be required to register their valid Digital Signature Certificate (Class II or Class III Certificates with signing key usage) issued by any Certifying Authority recognized by CCA India (e.g. Sify/TCS/nCode/eMudhra etc.) with their profile.**
- 1.5 Only one valid DSC should be registered by a bidder. Please note that the bidders are responsible to ensure that they do not lend their DSCs to others which may lead to misuse.
- 1.6 Bidder then logs in to the site through the secured log-in by entering their user ID/password and the password of the DSC/eToken.

2.0 Searching for Tender Documents

- 2.1 There are various search options built in the CPP Portal, to facilitate bidders to search active tenders by several parameters. These parameters could include Tender ID, organization name, location, date, value, etc. There is also an option of advanced search for tenders, wherein the bidders may combine a number of search parameters such as organization name, form of contract, location, date, other keywords etc. to search for a tender published on the CPP Portal.
- 2.2 Once the bidders have selected the tenders they are interested in, they may download the required documents / tender schedules. These tenders can be moved to the respective ‘My Tenders’ folder. This would enable the CPP Portal to intimate the bidders through SMS / e-mail in case there is any corrigendum issued to the tender document.
- 2.3 The bidder should make a note of the unique Tender ID assigned to each tender, in case they want to obtain any clarification / help from the Helpdesk.

3.0 Preparation of Bids

- 3.1 Bidder should take into account any corrigendum published on the tender document before submitting their bids.
- 3.2 Please go through the tender advertisement and the tender document carefully to understand the documents required to be submitted as part of the bid. Please note the number of covers in which the bid documents have to be submitted, the number of documents - including the names and 4 content of each of the document that need to be submitted. Any deviations from these may lead to rejection of the bid.
- 3.3 Bidder, in advance, should get ready the bid documents to be submitted as indicated in the tender document / schedule and generally, they can be in PDF/XLS/RAR/DWF formats. Bid documents may be scanned with 100 dpi with black and white option.
- 3.4 To avoid the time and effort required in uploading the same set of standard documents which are required to be submitted as a part of every bid, a provision of uploading such standard documents (e.g. PAN card copy, annual reports, auditor certificates etc.) has been provided to the bidders. Bidders can use “My Space” area available to them to upload such documents. These documents may be directly submitted from the “My Space” area while submitting a bid, and need not be uploaded again and again. This will lead to a reduction in the time required for bid submission process.
- 3.5 If any cell is left blank the same shall be treated as “0”. Therefore, if any cell is left blank and no rate is quoted by the bidder, rate of such item shall be treated as “0” (ZERO). However, if a tenderer quotes nil rates against each item in

item rate tender or does not quote any percentage above/below on the total amount of the tender or any section / sub head in percentage rate tender, the tender shall be treated as invalid and will not be considered as lowest tenderer.

4.0 Submission of Bids

- 4.1 Bidder should log into the site well in advance for bid submission so that he/she upload the bid in time i.e. on or before the bid submission time. Bidder will be responsible for any delay due to other issues.
- 4.2 The bidder has to digitally sign and upload the required bid documents one by one as indicated in the tender document.
- 4.3 Bidder shall submit tender fee as per critical data sheet.
- 4.4 A standard BOQ format has been provided with the tender document to be filled by all the bidders. Bidders are requested to note that they should necessarily submit their financial bids in the format provided and no other format is acceptable. Bidders are required to download the BOQ file, open it and complete the white coloured (unprotected) cells with their respective financial quotes and other details (such as name of the bidder). No other cells should be changed. Once the details have been completed, the bidder should save it and submit it online, without changing the filename. If the BOQ file is found to be modified by the bidder, the bid will be rejected.
- 4.5 The server time (which is displayed on the bidders' dashboard) will be considered as the standard time for referencing the deadlines for submission of the bids by the bidders, opening of bids etc. The bidders should follow this time during bid submission.
- 4.6 All the documents being submitted by the bidders would be encrypted using PKI encryption techniques to ensure the secrecy of the data. The data entered cannot be viewed by unauthorized persons until the time of bid opening. The confidentiality of the bids is maintained using the secured Socket Layer 128 bit encryption technology. Data storage encryption of sensitive fields is done.
- 4.7 The uploaded tender documents become readable only after the tender opening by the authorized bid openers.
- 4.8 Upon the successful and timely submission of bids, the portal will give a successful bid submission message & a bid summary will be displayed with the bid no. and the date & time of submission of the bid with all other relevant details.
- 4.9 Kindly add scanned PDF of all relevant documents in a single PDF file of compliance sheet.

5.0 Assistance to Bidders

- 5.1 Any queries relating to the tender document and the terms and conditions contained therein should be addressed to the Tender Inviting Authority to the address provided in Critical Data Sheet for a tender or the relevant contact person indicated in the tender.
- 5.2 Any queries relating to the process of online bid submission or queries relating to CPP Portal in general may be directed to the 24x7 CPP Portal Helpdesk. The contact number for the helpdesk is 0120-4001062 / 0120-4001002 / 0120-4001005 / 0120-6277787

6.0 General Instructions to the Bidders

- 6.1 The tenders will be received online through portal <http://eprocure.gov.in/eprocure/app>. In the Technical Bids, the bidders are required to upload all the eligibility criteria documents in .pdf format.
- 6.2 Possession of a Valid Class II/III Digital Signature Certificate (DSC) in the form of smart card/etoken in the company's name is a prerequisite for registration and participating in the bid submission activities through <https://eprocure.gov.in/eprocure/app>. Digital Signature Certificates can be obtained from the authorized certifying agencies, details of which are available in the web site <https://eprocure.gov.in/eprocure/app> under the link "Information about DSC".
- 6.3 Tenderer are advised to follow the instructions provided in the 'Instructions to the Tenderer for the e-submission of the bids online through the Central Public Procurement Portal for e-Procurement at <https://eprocure.gov.in/eprocure/app>.

INFORMATION AND INSTRUCTIONS TO BIDDERS

On behalf of BOG, I.I.T. Roorkee, online Tenders (Percentage Rate) are invited in two Bid systems (Technical and Financial) from eligible bidders of appropriate class & category registered with CPWD, State PWD, MES, having experience of working in Central / State Government, Public Sector Undertaking / Autonomous Organization of Central / State Government and Working Contractors of IITR who fulfil the PQ criteria for the work of **“Supply, Installation, Testing and Commissioning of 13 Passenger and service (Goods cum Passenger) MRL Lifts with 8 stops for G+7 Building in the existing shaft including dismantling, removal and buyback of existing lift with accessories at Hill View Apartment & RK Bhawan at IIT Roorkee”**

- 1.1 The work is estimated to cost as mentioned in the NIT. The estimate however, is given merely as a rough guide.
- 1.2 Intending bidder is eligible to submit the bid provided, if he has definite proof from the appropriate authority, which shall be to the satisfaction of the competent authority, of having satisfactorily completed similar works of magnitude specified below:

1.2.1 Criteria of eligibility for submission of bid documents:

- (a) Intending bidder should not be a joint venture (Self Certified copy of relevant documents clearly establishing the status of bidder to be uploaded in Cover-1).
- (b) Should have successfully completed works during last seven years ending last day of the month previous to the one in which applications are invited. **The works completed up to previous day of last date of submission of tenders shall also be considered.**

Three similar completed works costing not less than the amount equal to 40% of the estimated cost put to tender,

or

Two similar completed works costing not less than the amount equal to 60% of the estimated cost put to tender.

or

One similar completed work of aggregate cost not less than the amount equal to 80% of the estimated cost.

(Self-Certified photocopy of work order along with work completion certificate to be uploaded as proof of eligibility criteria in Cover-1)

Work completion certificate should have been issued by an officer not less than the rank of Executive Engineer / equivalent and must contain name of the work, date of start, date of actual completion and amount of work executed.

Explanation: The value of executed works shall be brought to current costing level by enhancing the actual value of work at simple rate of 7% per annum; calculated from the date of completion to last date of receipt of applications for this tender.

Similar work means **“SITC/ Replacement of Lifts including civil structure work”**.

- (c) Average annual financial turn over should be at least 50% of the estimated cost during last three consecutive financial years duly audited by a Chartered Accountant (Self Certified copy of certificate from CA to be uploaded in Cover-1). The year in which no turnover is shown would also be considered for working out the average.
 - (d) Should have valid solvency certificate of the amount at least 40% of the estimated cost of the work issued by a scheduled bank which is not more than **one year old** from the last date of tender submission (including extension time). Certified copy of original solvency certificate to be uploaded in Cover-1.
2. Agreement shall be drawn with the successful bidder on prescribed format.
 3. The time allowed for carrying out the work will be as per the NIT from the date of start as defined in Award of Work or from the first date of handing over of the site, whichever is later, in accordance with the phasing, if any, indicated in tender documents.
 4. The site for the work is available / shall be made available for start of the work.
 5. The Tender document consisting of plans, specifications, the schedule of quantities of various types of items to be executed and the set of terms and conditions of the contract to be complied with and other necessary documents can be seen / downloaded from IIT Roorkee website: www.iitr.ac.in (<http://mm.iitr.ac.in/mmweb/tenders>) or from Central Public Procurement Portal (CPPP) <https://eprocure.gov.in/eprocure/app>.

6. While submitting the bids, bidder can revise the rate, but before last date and time of submission of bids as notified. In this case, the last submitted bid before the last date and time will only be considered.
7. The scanned copies of documents as per critical data sheet shall be uploaded under Cover-1 on the e-tendering website.
8. Online Financial Bids submitted by intending bidders shall be opened only of those bidders, whose bid found technically qualified.
9. The bid submitted shall become invalid and cost of bid & tender processing fee shall not be refunded if: (i) the bidder is found ineligible. (ii) The bidder does not provide all the documents (including PAN No., GST registration etc.) as stipulated in the bid document.
10. Intending bidders are advised to inspect and examine the site and its surroundings and satisfy themselves before submitting their bids as to the nature of the ground and sub-soil (so far as is practicable), the form and nature of the site, the means of access to the site, the accommodation they may require and in general shall themselves obtain all necessary information as to risks, contingencies and other circumstances which may influence or affect their Tender. A bidder shall be deemed to have full knowledge of the site whether he inspects it or not and no extra charge consequent upon any misunderstanding or otherwise shall be allowed. The bidder shall be responsible for arranging and maintaining at his own cost all materials, tools & plants, water, electricity access, facilities for workers and all other services required for executing the work unless otherwise specifically provided for in the contract documents. Submission of a tender by a bidder implies that he has read this notice and all other contract documents and has made himself aware of the scope and specifications of the work to be done and of conditions and rates at which stores, tools and plant, etc. will be issued to him by the Institute and local conditions and other factors having a bearing on the execution of the work. Cost of site visit shall be borne by the bidder.
11. All tenders in which any of the prescribed condition is not fulfilled or any condition including that of conditional rebate is put forth by the bidder shall be summarily rejected.
12. Canvassing whether directly or indirectly, in connection with bidders is strictly prohibited and the Tenders submitted by the bidders who resort to canvassing will be liable to rejection.
13. The bidder shall not be permitted to tender for works in the IWD, IIT Roorkee, if his near relative is posted as an officer in any capacity between the grades of Dean Infrastructure and Junior Engineer (both inclusive). Any breach of this condition by the bidder would render him liable to be removed from the Tendering process.
14. No Engineer of gazetted rank or other Gazetted Officer employed in Engineering or Administrative duties in an Engineering Department of the Government of India is allowed to act as a bidder within a period of one year after his retirement from Government service, without the previous permission of the Government of India in writing. This contract is liable to be cancelled if either the bidder or any of his employees is found any time to be such a person who had not obtained the permission of the Government of India as aforesaid before submission of the tender or engagement in the bidder's service.
15. The notice inviting bid shall form part of the contract document. The successful bidder, on acceptance of his bid by the Accepting Authority, have to sign the contract consisting of "The Notice Inviting bid, all the documents including Special Conditions, General Specifications/ Particular Specifications and drawings, if any, forming part of the bid as submitted at the time of invitation of bid and the rates quoted online at the time of submission of bid and acceptance thereof together with any correspondence leading thereto within 15 days from the stipulated date of start of the work.
16. The bid for the works shall remain open for acceptance for a period of 90 days from the date of opening of financial bids. If any bidder withdraws his bid before the said period or issue of letter of acceptance, whichever is earlier, or makes any modifications in the terms and conditions of the bid which are not acceptable to the Indian Institute of Technology Roorkee, then Indian Institute of Technology Roorkee, without prejudice to any other right or remedy, be at liberty to forfeit of the said earnest money as aforesaid. Further, the bidder(s) shall not be allowed to participate in the re-bidding process of the work.
17. **Composite Tender (if applicable)**
 - 17.1 The competent authority is calling this bid for the composite work. The Earnest money is fixed with respect to the combined estimated cost put to tender for the composite tender.
 - 17.2 The eligible bidders have to quote rates for all items given in the schedule of quantity.
 - 17.3 After acceptance of the bid by competent authority, **Institute Engineer, IWD, IIT Roorkee** shall issue letter of Acceptance (LoA) on behalf of the Institute. After issue of LoA, the bidder will have to enter into one agreement with **Institute Engineer**.
 - 17.4 Entire work under the scope of composite tender including major and all minor components shall be executed under one agreement.

- 17.5 Security Deposit will be worked out separately for each component corresponding to the quoted/accepted cost of the respective component of works. The Earnest Money will become part of the security deposit of the respective projects under the head Mega projects in ratio of the corresponding estimated value of these projects.
- 17.6 The bidder may associate agency(s) for minor component(s) conforming to eligibility criteria as defined in the tender document and has to submit detail of such agency(s) to Dean Infrastructure. Name of the agency(s) to be associated shall be approved by Dean Infrastructure. Before engaging such associate agencies bidder has to inform to Dean Infrastructure along with his past experience and all credential's and got the approval of the same from him.
- 17.7 In case the bidder intends to change any of the above agency/ agencies during the operation of the contract, he shall obtain prior approval of respective Dean Infrastructure. The new agency/ agencies shall also have to satisfy the laid down eligibility criteria. In case Dean Infrastructure is not satisfied with the performance of any agency, he can direct the bidder to change the agency, and this shall be binding on the bidder.
- 17.8 The main bidder has to enter into agreement with bidder(s) associated by him for execution of minor component(s). Copy of such agreement shall be submitted to Engineer-in-charge In case of change of associate bidder, the main bidder has to enter into agreement with the new bidder associated by him.
- 17.9 The composite work shall be treated as complete when all the components of the work are complete. The completion certificate of the composite work shall be recorded by Engineer-in-charge of major component after record of completion certificate of all other components. Final bill of whole work shall be finalized by IWD, IIT Roorkee.
- 17.10 It will be obligatory on the part of the bidder to sign the tender documents for all components before the first payment is released.

A: GENERAL INSTRUCTIONS

1. Scope of Tender.

- 1.1 Indian Institute of Technology Roorkee (referred to as Owner in these documents) invites Tender as defined in these documents and referred to as “the works” detailed in the table given in the Notice Inviting Tenders (NIT).
- 1.2 The successful Bidder shall complete the works within the completion date specified in the Notice Inviting Tenders (NIT).

2. Non-Association / Relation

- 2.1 All bidders shall provide in the bid tender and Qualification Information, a statement that the Bidder is not associated, nor has been associated in the past, directly or indirectly, with the Indian Institute of Technology Roorkee or any other entity that has prepared the design, specifications, and other documents for the Project.

3. Qualification of the Bidder

- 3.1 All Bidders shall provide tender qualification information.
- 3.2 All Bidders shall include the following information by submitting relevant documents and certificate with their tenders: The Bidder must be registered with the GST Department and should submit the registration certificate of GST, ESI, EPF, Labour License (if applicable) etc.

4. Cost of tendering

- 4.1 The Bidder shall bear all costs associated with the preparation and submission of his tender, and the Owner will in no case be responsible and liable for those costs.
- 4.2 The Bidder, at its own responsibility and risk is encouraged to visit and examine the Site of Work and its surroundings and obtain all information that may be necessary for preparing the tender. The costs of visiting the Site shall be at the Bidder’s own expense.

B: DOCUMENTS INVITING TENDERS

5. Invitation: Tenders are hereby invited on behalf of Indian Institute of Technology Roorkee.

6. Contents of documents as mentioned in the relevant clauses mentioned:

The Bidder shall be deemed to have examined all instructions, forms, terms, and specifications in the Documents. Failure to furnish the information required in the Tender Document or submission of a Bid not substantially responsive to the Tender Documents in every respect will be at the Bidder’s risk and may result in the rejection of the bid.

The several documents forming the contract are to be taken as mutually explanatory of one another, detailed drawings being followed in preference to small scale drawing and figured dimensions in preference to scale and Special Conditions in preference to General Conditions.

In case of any discrepancy between the Schedule of Quantities, the specifications and/ or the drawings, given in the tender document the following order of preference shall be observed:

1. Description of Schedule of Quantities.
2. Particular Specification and Special condition, if any.
3. Drawings.
4. C. P. W. D. specifications/ IWD, IIT ROORKEE specification.
5. Latest edition Indian Standard Specifications of B. I. S.

7. Amendment of Tendering Documents

- 7.1 Before the deadline for submission of bids, the Indian Institute of Technology Roorkee may modify the Tender documents by issuing addenda/corrigendum.
- 7.2 Any addendum thus issued shall be part of the Tendering documents and shall be uploaded on e-Tendering website <https://eprocure.gov.in/eprocure/app> and Institute website <http://mm.iitr.ac.in/mmweb/tenders>.
- 7.3 To give prospective Bidders reasonable time in which to take an addendum / corrigendum into account in preparing their bid, the IIT Roorkee may extend if necessary the deadline for submission of tenders.

C: PREPARATION OF DOCUMENT

8. **Earnest Money Deposit (EMD):** EMD as per critical data sheet must be submitted. Bids not accompanying with EMD will be summarily rejected. The EMD of the unsuccessful Bidders will be discharged / returned within Thirty (30) days from the date of opening of the financial bids. The EMD of the successful Bidder shall be converted as Security deposit. The EMD may be forfeited and further the bidder shall not be allowed to participate in the re-bidding process of the work, if the Bidder withdraws his bid during bid validity period or in case successful Bidder fails to sign the contract / fail to deposit security amount and performance guarantee.
9. **Period of validity of bid:** The bids shall remain valid for a period of 90 days after the date of financial bid / price bid opening. A bid valid for a shorter period shall be rejected by the Indian Institute of Technology Roorkee as non-responsive.
10. **Language of Bid:** The document shall be written in English/Hindi language. The total amount should be written in the same language.
11. **Document comprising the E-Tender:** No page of this tenders document shall be removed and the set must be submitted as it is. Each page of the tenders document form is to be signed by the Bidder and must bear the Seal of the Company/Firm.

The tender submitted by the Bidder shall comprise as mentioned above in the relevant sections.

12. Tender Prices

- 12.1 The contract shall be for the whole works as described in priced Schedule of Quantities submitted by the Bidder.
- 12.2 The tender submitted on behalf of firm shall be signed by a person who has the proper legal authority on behalf of the firm to enter into the contract; otherwise, the bid is liable to be rejected. Each page of the tender document and each drawing accompanying is required to be signed by the authorized person submitting the bid, with the company seal as the token of their having examined and acquainted themselves with the General conditions of contract, drawings, specifications, special conditions of contract etc. The forms of tender are to be filled in completely. Any bid with any of the documents not signed is liable to be rejected.
- 12.3 The notation R.O. written against items of BOQ means 'rate only' and the bidder is to quote only unit rate in such cases.
- 12.4 The Bidder shall fill in the percentage rate/in rates for items of the Works described in the Schedule of Quantities along with total bidding price. In case if the rates are not filled for any of the Items of Schedule of Quantities, in such cases the tender shall be summarily rejected. Failure to comply with either of these conditions will make the bid liable for rejection.
- 12.5 **Taxes:** All duties, taxes, and other levies payable by the Bidder under the contract, or for any other cause, shall be included in the rates, prices and total Bidding Price submitted by the Bidder. Bidders must include in their rates, the cost of transportation of materials to site, GST, labour cess as per Building & other construction workers cess act, excise duty, octroi, and any other tax and duty levied by the Central / State Government. None of the above taxes & levies will be entertained by the Owner and no tax exemption forms will be issued by the Owner.
Estimate has been prepared on current applicable GST rate. However actual payment will be done on the basis of prevailing GST rates at the time of execution of work and its payment.
- 12.6 **Labor Cess or BOCWW Cess:** Labour cess @1% shall be deducted from each bill.
- 12.7 The work shall be carried out by the Bidder in a manner complying in all respect with the requirement of relevant bye-laws/orders of the Local/Municipal bodies and pay all fees and charges which may be leviable at his own cost. The completion/ occupancy certificates including clearance from fire committee or any other statutory obligation shall be arranged by the bidder. Any official fees shall be paid by the Owner. All other cost of liasoning shall be borne by the bidder.
- 12.8 Bidder should also take a Group Insurance Policy for his Workmen, Supervisors and Engineers working on site for an adequate insurance cover. Indian Institute of Technology Roorkee shall not be responsible for any accident or happening of any untoward/unforeseen event involving workmen, labour, supervisor or Engineer or any person directly or indirectly associated with the execution of work. The insurance policy to be obtained by the successful Bidder must be comprehensive and shall cover all associated risks (known and unknown).

- 12.9 The rates quoted in the tender shall include cost of electrical power supply, water supply, cost of all materials, labour, telephone, rent and call charges, water and meter rent charges, temporary electric wiring / lighting for execution of work at site, hire for any tools and plants, shed for materials, marking out and clearing of site, transportation complete in all respects. The rates quoted in the tender shall be treated as rate for finally completing the item of work.
- 12.10 The quantities furnished in the schedule of quantities are only probable quantities and are liable to alterations, by omission, deductions or additions to any extent at the discretion of Indian Institute of Technology Roorkee. Payments will be regulated on the actual quantities of work done at accepted rates.
- 12.11 Errors in the Schedule of Quantities shall be dealt with in the following manner:
- i. In the event of a discrepancy between the rates quoted in words and the rates in figures, rate quoted in words shall be considered to be correct.
 - ii. In the event of an error occurring on account of arithmetical calculations the same shall be corrected according to rates written in words and quantities in B.O.Q.
 - iii. All the errors in totaling in the amount column and in carrying forward the totals shall be corrected. The tender total shall be accordingly amended. If the bidder doesn't accept the corrected amount, then his bid will be rejected.
- 12.12 The calculations made by the bidder should be based upon quantities of the items of work which are furnished in the Schedule of Quantities, but it must be clearly understood that the contract is not a lump sum contract. The Owners do not in any way assure, represent or guarantee that the said probable quantities are correct or that the work would correspond thereto. The items of work irrespective of the quantities which may vary shall be carried out at the same accepted bidding tender rates and no escalation in the rates will be entertained whatsoever. Any item of work may be omitted from the schedule of quantities and may be awarded to another agency at any time / stage of the work.
- 12.13 The bidders must obtain for themselves on their own responsibility and their own expenses all the information which may be necessary, including risks, contingencies and other circumstances to enable them in making a proper bid and for entering into a contract, and must examine the drawings, specifications and conditions and inspect the site of the work, nature of the work, availability of power, water, shelter for workmen and all the matters pertaining thereto before submitting the bid. They can also get any clarifications required from the Owner, before tendering, by contacting them at their office during working hours.

13. Format and signing of Tender document

- 13.1 The bid shall be typed or written in indelible ink and shall be signed by a person or persons duly authorized to sign on behalf of the Bidder. All pages of the tender where entries or amendments have been made shall be initialed by the person or persons signing the tender.
- 13.2 The tender shall contain no alterations or additions, except those to comply with instructions issued by the Owner, or as necessary to correct errors made by the Bidder, in which case such corrections shall be initialed by the person or persons signing the bid. ANY CONDITIONAL BID WILL BE SUMMARILY REJECTED.

D: MODE OF SUBMISSION OF BID DOCUMENT

14. Sealing and marking of bids.

- 14.1 The entire document to be put in cover-1 and 2 should be scanned and uploaded under cover-1 and 2 respectively on the e-tendering website. No hard copy of any document (financial or technical) should be submitted. In case any hardcopy is submitted then the same will not accepted by the department.

15. Deadline for submission of bid: - As per Critical Data Sheet.

E: TENDER OPENING AND EVALUATION

- 16. Tender opening:** The tender will be opened on the date and the place specified in the critical data sheet. In case of any unavoidable circumstances or unforeseen event on the specified date and time of tender opening, the bids will be opened at the appointed time and location on the next working day.

17. **Clarification of Tenders:** To assist in the examination, evaluation and comparison of bids, the Owner may, at his discretion, ask any Bidder for clarification of his bid, including breakdowns of unit rates. The request for clarification and the response shall be in writing or by fax, but no change in the price or substance of the tendering shall be sought, offered, or permitted.
18. **Examination of Bids and Determination of Responsiveness:**
- 18.1 Prior to the detailed evaluation of bids, the Owner will determine whether each bid
- Meets the eligibility criteria defined
 - Has been properly signed and meets the requirements mentioned
 - is accompanied by the required securities and;
 - is responsive to the requirements of the tendering documents.
- 18.2 A responsive bid is one which conforms to all the terms, conditions and specifications of the tendering documents, without material deviation or reservation. A material deviation or reservation is one
- Which affects in any substantial way the scope, quality, or performance of the works;
 - which limits in any substantial way, inconsistent with the tender documents, the Indian Institute of Technology Roorkee rights or the Bidders' obligations under the contract; or
 - Whose rectification would affect unfairly the competitive position of other Bidders presenting responsive bids.
- 18.3 If a bid is not responsive, it will be rejected by the Indian Institute of Technology Roorkee, and may not subsequently be made responsive by correction or withdrawal of the nonconforming deviation or reservation.
19. **Evaluation and Comparison of Bids:**
- 19.1 The Owner along will evaluate and compare only the bids determined to be substantially responsive.
- 19.2 In evaluating the bids, the Owner will determine for each bid the evaluated bids Price by adjusting the bid. Price as follows:
- Making any correction for errors; or
 - Making an appropriate adjustment for any other acceptable variations, deviations; and
 - Making appropriate adjustments to reflect discounts offered.
20. **The Owner reserves the right to accept or reject any variation, deviation, or alternative offer and other factors which are in excess of the requirement of the tender.**

F: AWARD OF TENDER

21. **Award criteria:**
- 21.1 The acceptance of bid will rest with the Owner, which does not bind itself to accept the lowest bid and reserves to itself the authority to reject completely / partially, any or all of the bid/s received without the assignment of a reason.
- 21.2 The owner reserves to itself the right of accepting the whole or any part of the Bid and the Bidder shall be bound to perform the same at the rate quoted.
- 21.3 The Owner reserves to itself the right of omission of any item of work from the awarded tender at any time / stage during the execution of work and awards the same to another agency / bidder.
22. **Notification of award:** The successful Bidder will be issued a Letter of Acceptance (LoA) by the Owner. The issuance of LoA shall not constitute an award of work.
23. **Performance Guarantee:** Within ten (10) days of LoA the successful Bidder shall furnish the performance guarantee @ 5% of value of work in the form of DD/FDR/ Bankers cheque /Bank Guarantee from Scheduled bank provided in the tender document. The Performance Guarantee must be valid two months beyond the work completion period. It may be further extended. The Performance guarantee shall be returned / refunded to the bidder on completion of the work and recording of the completion certificate. In case the bidder fails to deposit it the said performance guarantee within the period as indicated, the Earnest Money deposited by the bidder shall be forfeited automatically without any notice to the bidder.
24. **Signing of contract form:** On the acceptance of LoA and Performance Bank Guarantee of the successful Bidder whose tender has been accepted in writing, the Indian Institute of Technology Roorkee will sign an agreement. Article of agreement shall be as per IIT Roorkee.

G: DURING EXECUTION

- 25. During Execution:** The Bidder shall carry out all the works strictly in accordance with the drawing, details and instructions of the Owner. If in the opinion of the Owner, changes have to be made in the design, and they desire the bidder to carry out the same, the Bidder shall be bound to comply. The Owner decisions in such cases shall be final.

The Bidder is bound to carry out any items of work necessary for the completion of the job even though such items are not included in the schedule of quantities and rates. Schedule of instructions in respect of such additional items and their quantities with the prior consent from the Owner. Rates for such items of work will be approved by the Owner on the basis of Analysis of Rates which will be derived from actual prevailing market rates of similar item along with 15% as bidder's profit & overhead (or service charge as quoted by the bidder). The rates approved by the Owner in such cases will be final.

The Bidder shall get the quality of work done inspected for material and workmanship at different stages of execution as per instructions given by the Owner or their representative time to time. Any item of work done which is found not conforming to the Contract shall be rejected by the Owner. The decision of the Owner in such cases shall be final.

The Owner may instruct at any stage of execution for testing of samples of any material taken at random. The Owner will decide the testing laboratory / agency and the cost of testing including the expenses for sending the samples to the laboratory / agency and receipt of test reports shall be borne by the Bidder. The material shall be rejected in case the test reports are not within the permissible limits.

The Bidder shall have to present the invoice for purchased material from the manufacturer or from the dealer along with the certificate from the manufacturer. In case material is found to be of substandard quality, the same shall be rejected by the Owner. The decision of the Owner in such cases shall be final.

The Bidder shall not be entitled to any compensation for the Loss suffered by him on account of delays in commencing or executing the work whatever the cause of delay may be, including delays arising out of modifications to the work entrusted to him or in any subcontracts connected therewith or delays in awarding contracts for other trades of the project or in commencement or completion of such other works or in procuring Government controlled or other building materials for any other reasons whatsoever. The Owner shall not be liable for any sum besides the e-tender amount, subject to such variations as are provided for herein and as instructed by Owner. However, necessary time extension will be given if the delays are not attributed to the Bidder.

QUALIFYING INFORMATION

Please furnish the following information along with documentary evidence only in this format (as eligibility criteria)

1.	Name of the bidder		
2.	Legal Status of the bidder		
3.	Place of registration and registration of the bidder		
4.	Year of establishment of the firm.		
5.	Permanent Address		
6.	Email id		
7.	Contact Numbers		
8.	Principal place of the registration		
9.	PAN No.		
10.	GST No.		
11.	EPF		
12.	ESI		
13.	Tender fee details		
14.	Solvency certificate details		

16. Average annual financial turnover during the last 3 years, ending 31st March of previous financial year, should not be less than 50% of the estimated cost. CA certificate be enclosed as documentary proof. Copies of balance sheets duly certified by **CA preferably with UDIN Number** to be submitted.

Sl. No.	Financial Year	Amount (in Lakhs)
1	2021-2022	
2	2022-2023	
3	2023-2024	

17. PROFORMA FOR LIST OF WORKS EXECUTED BY THE BIDDER DURING THE LAST 5 YEARS AND ABOVE

Sl. No	Name of work/ project with address	Name & postal address of the owner & contact person	Contract Value	Date of Start	Date of Completion	Actual Date of Completion

Note: Bidder may furnish the above information in separate sheet if the space is not sufficient.

18. PROFORMA FOR LIST OF WORKS IN HAND

Sl. No	Name of work/ project with address	Name & postal address of the owner & contact person	Published Value	Date of Start	Stipulated date of completion	Present Progress

Note: Bidder may furnish the above information in separate sheet if the space is not sufficient

19. DETAILS OF KEY PERSONNEL

Sl. No	Name & Designation	Qualification	Experience	Nature of Works Handled	Date from which employed in your organization

Note: Bidder may furnish the above information in separate sheet if the space is not sufficient.

20. List of equipments, tools and tackles (in applicable).

GENERAL CONDITIONS OF CONTRACT(GCC)

A: GENERAL

1.0 Definitions:

- 1.1 In this contract, the following terms shall be interpreted as indicated:
- a. "The Contract" means the agreement entered into between the Owner and the Bidder, as recorded in the contract form signed by the parties, including all the attachments and appendices thereto and all documents incorporated by reference therein.
 - b. "The Contract Value" means the amount payable to the Bidder under the contract for the full and proper performance of its contractual obligations.
 - c. "Contract Data" means any information provided in the tender document and agreed to by the Bidder.
 - d. "The Work" means all labour, materials, tools and plant, equipment including government taxes and transport that may be required in preparation of and for and in the full and entire execution and completion of "the Work".
 - e. "Services" means services ancillary to the execution of the work such as transportation and insurance, and any other incidental services, such as installation, commissioning, provision of technical assistance, training and other obligations of the Bidder covered under the contract.
 - f. "GCC" mean the General Conditions of Contract contained in this section.
 - g. "SCC" means the Special Conditions of Contract.
 - h. "The Owner" means the Indian Institute of Technology Roorkee or its representative.
 - i. "The Owner" means the Owner/Project Management Consultant appointed by the Owner for preparing all the drawings, details and specifications of items required for the execution of the work and supervise and monitor the execution at site along with checking and verifying Bidder's bill. The Bidder shall offer the Engineer or any representative of Owner every facility and assistance for examining the works and materials. The Engineer or any representative of the Owner shall have power to give notice to the Bidder or to his staff, of non-approval of any work or materials and such work shall be suspended or the use of such materials shall be discontinued until the decision of the Owner. Such examinations shall not in any way exonerate the bidder from the obligations to remedy any defects which may be found to exist at any stage of the work or after the same is completed.
 - j. "The Bidder" means the individual or the firm executing the work.
 - k. "The Project Site" where applicable, means the place or places named in SCC.
 - l. "Day" means calendar day.
 - m. "Engineer-in-charge (EIC)" means Assistant Executive Engineer.

2.0 Interpretation and Application

- 2.1 These general conditions shall apply to the extent that provisions in other parts of the contract do not supersede them.
- 2.2 In interpreting these Conditions of Contract, singular also means plural, male also means female or neuter, and the other way around. Headings have no significance. Words have their normal meaning under the language of the Contract unless specifically defined. The Owner will provide instructions clarifying queries about the Conditions of Contract.
- 2.3 If sectional completion is specified in the Contract Data, references in the Conditions of Contract to the Works, the Completion Date, and the Intended completion date are for the whole of the Works.

3.0 Standards

- 3.1 The works executed by the Bidder should be carried out in most professional manner, both as regards material and otherwise, in every respect, in strict accordance with the Technical Specifications. All materials and workmanship shall so far as procurable be of the respective kinds described in the priced schedule of quantities and/ or specifications and in accordance with the Owner' instructions, and the Bidder shall upon the request of the Owner, furnish them with all invoices, accounts; receipts and other vouchers to prove that the material

procured complies therewith. When no applicable standard is mentioned, the work shall be carried out as per the directions of the Owner. The Bidder shall at his own cost arrange for and/or carry out any test of materials which the Owner may require. In case of discrepancies in tender wording as regards the specifications of materials, workmanship etc., written instructions will supersede the tender wording unless otherwise mentioned.

- 3.2 The Owner in their absolute discretion from time to time shall issue further drawings and/ or written instructions, details, directions and explanations which are hereafter collectively referred to as “the Owner’s instructions” in regard to: -
- a. The variation or modification of the design quality or quantity of works or the addition or omission or submission on any work.
 - b. Any discrepancy in the drawings or between the schedule of quantities and / or drawings and /or specifications/ dimensions etc.
 - c. The removal and / or re-execution of any works executed by the Bidder.
 - d. The removal from the site of any materials brought thereon by the Bidder and the substitution of any other materials therefore / or rejection of the material brought on site.

4.0 Use of Contract Documents and Information

- 4.1 The Bidder shall not, without the Owners’ prior written consent, disclose the contract or any provision thereof, or any specifications, plan, drawing, pattern, sample or information furnished by or on behalf of the Owner in connection therewith, to any person other than a person employed by the Bidder in performance of the contract. Disclosure to any such employed person shall be made in confidence and shall extend only so far, as may be necessary for purposes of such performance.
- 4.2 The Bidder shall not, without the Owner’s prior written consent make use of any document or information enumerated in Para 4.1 except for the purposes of performing the contract.
- 4.3 All documents included but not limited to contract agreement shall remain the property of the Owner and shall be returned (in all copies) to the Owner on completion of the Bidder’s performance under the contract, if so required by the Owner.

5.0 Owner’s Decisions: Except where otherwise specifically stated, the Owner will decide contractual matters between the Owner and the Bidder, in the role of representing the Owner.

6.0 Performance Guarantee: The proceeds of the performance guarantee shall be payable to the Owner as compensation for any loss or dues resulting from the Bidder’s failure to complete its obligations under the contract.

7.0 Program and Reporting

- 7.1 The bidder shall furnish to the Indian Institute of Technology Roorkee a bar chart laying down weekly financial and physical targets to complete the project within stipulated time for approval within fifteen days from the date of receipt of notification of award. Weekly progress report shall be furnished to the owner showing the progress.
- 7.2 The bidder must submit every week the following information to the Owner in writing:
 - i. Number of men employed, trade wise;
 - ii. Progress achieved;
 - iii. Expected dates for completion of work;
 - iv. Any actual or potential delay in completion schedule.

8.0 Assignment and Sub-contracting

- 8.1 The whole of the works included in the Contract shall be executed by the bidder and the bidder shall not directly or indirectly transfer, assign or underlet the contract or any part, share or interest therein without the written consent of the Owner.
- 8.2 No sub-contracting shall relieve the Bidder from the full and entire responsibility of the Contract or from the active superintendence of the work during their progress.

9.0 Bidder to provide everything necessary for proper execution of work

- 9.1 The Bidder shall provide everything necessary for the proper execution of the works according to the intent and meaning of the drawings, priced schedule of quantities and specifications taken together whether the same may or may not be particularly shown or described therein provided that the same can reasonably be inferred there from. If the Bidder finds any discrepancy therein he shall immediately and in writing refer the same to the Owner whose decision shall be final and binding. Further, if any sample(s) of material(s), fittings, fixtures or finished item(s), to be used in the construction work, has/have been called for from the bidder, no work related to it/these shall be executed unless the same has/ have been approved by the Owner failing which no payment shall be made to the bidder on this account. Any sample, duly approved by the Owner shall become part of the supply to be used in “the works”.
- 9.2 IIT Roorkee will provide water and power supply at site free of cost for the entire work.
- 9.3 The Bidder shall supply fix and maintain at his cost, during the execution of any works, all the necessary power supply, water supply, centering, scaffolding, watching and lighting by night as well as by day, required not only for the proper execution but also for protection of the public and the safety of any adjacent roads, streets, pavements, walls houses, building and other erections, matters or things. The Bidder shall take down and remove any or all such centering, scaffolding, staging, planking, timbering, strutting, shoring pumping, fencing, hoarding, watching and lighting by night as well as by day, required not only for the proper execution but also for protection of the public and the safety of any adjacent roads, streets, pavements, walls houses, building and other erections matters or things. The bidder shall take down and remove any or all such centering, scaffolding, staging, planking, timbering, strutting, shoring etc. as occasion shall require or when ordered so to do so and shall fully reinstate and make good all matters and things disturbed during the execution of the works, to the satisfaction of the Owner.
- 9.4 Throughout the execution of the work, the Bidder or his representative duly authorized and fully responsible and technically conversant with the work under this agreement, acting on his behalf shall be available at the site for supervising the work. The Bidder shall make adequate arrangements for watchmen to guard the materials brought by them to the site and shall ensure the safety, breakage and any theft of materials fixed or unfixed by him. Any material, T & P brought to the site for bonafide use of the Project shall not be removed/ shifted from the site without the prior written permission of the Engineer/Owner.
- 9.5 The bidder has to provide at his cost leveling pipe, steel/ metallic tapes etc. required by the supervising staff of the Owner's/Owner' representative during execution of the work.
- 9.6 Whenever required by the Owner, the Bidder shall provide electrical drawings / details before execution of work and get them approved by the Owner.
- 9.7 Wherever the specification of any item indicates the usage of approved equivalent of any material, the Bidder shall get the sample of the equivalent material approved from the Owner before execution. The approval of the equivalent material is entirely at the discretion of the Owner.

10.0 Infrastructure: For storage of materials, bidder has to provide at his own cost sufficient fenced and covered appropriate area on site for storage of above materials with lock and key arrangement. For arranging meetings suitable sized table and chairs shall be provided by Bidder. Temporary space shall be provided to the Bidder for construction of stores for storage of materials /site office/ labour hutments for the project period.

11.0 Site Establishment: The bidder shall provide all stores, workmen and materials. All materials likely to deteriorate in the open shall be stored under suitable cover. The security of the bidder's equipment and materials is his own responsibility. The Owner accepts no liability for loss or damage to the bidder's plant tools or materials. The materials issued to the bidder by the Owner will remain under the custody of bidder as a trustee. However, title on the same will remain with the Owner. The bidder will be responsible for loss or damage to such materials and shall preserve them in good working conditions as required for the contract and good construction practices till such time that they are incorporated in the works and erected, aligned and fully installed in position and handed over to the Owner. In case the Owner feels that arrangements made by the bidder are not adequate he shall so advice the bidder and the bidder shall promptly take corrective action. In case the bidder fails to take corrective action, Owner shall take such corrective actions and recover the cost thereof from the bidder's bills. Accounts of such material on completion of work shall be rendered and surplus material returned to the Owner as per instructions of Owner. The bidder shall clear away

periodically or as instructed by Owner any rubbish, scrap materials, etc. and dump the same in the authorized dump sites notified by local authority/area indicated by the Owner. All construction materials shall be neatly stacked in an orderly manner as directed by the Owner and care shall be taken to allow proper access to workmen and easy movement of men, vehicles, cranes and materials. The bidder shall maintain all the drawings carefully mounted on the board of appropriate size and well protected from the ravages of weather, termites and other insects. The bidder shall not permit the entry to the site of any person not directly connected/concerned with the work without first having obtained the written permission of Owner. The bidder shall submit a list of plants, equipments, tools, tackles, etc. which he will use, to perform the work. These tools, etc. shall not be removed from the site till the completion of job. A gate pass must be obtained from the Indian Institute of Technology Roorkee, chief proctor office, in order to remove from site any plant equipment, tools and materials. All items such as instructions and other pertinent data regarding erection/commissioning and maintenance should be typed and classified for transmittal in a manner approved by the Owner. For all employees of Owner, the bidder shall conform for no misconduct from any of his workforce; failure of this will be sufficient cause for removal of such person from the site.

12.0 Messing & Accommodation: The bidder will make his own arrangements for messing and accommodation. No accommodation and messing shall be provided by the Owner.

13.0 Procurement, Consumption and Storage of Materials

- 13.1 The bidder shall at his own expenses, provide all materials including cement & steel required for the works. Adequate stocks of all materials required for the work are to be maintained at site. No material (unless as provided elsewhere in this document) shall be supplied by the Owner.
- 13.2 All materials to be provided by the bidder shall be in conformity with the detailed specifications laid down in the contract and the bidder have to prove that the materials conform to the laid down specifications, if requested by the Indian Institute of Technology Roorkee.
- 13.3 All materials required for execution of work must be got approved by the site representative of the Owner before they are actually put to use. All facilities for prior inspection of materials and subsequent inspection of work by the Site Engineer must be made available.
- 13.4 The bidder shall, at his own expenses and without delay, supply to the Owner samples of materials proposed to be used in the work. The Owner shall within seven days of supply of samples, or within such further period as Owner may require and intimate the bidder in writing, whether samples are approved by Owner, or not. If samples are not approved, the bidder shall forthwith arrange to supply, for their approval, fresh samples complying with the specification laid down in the contract.
- 13.5 The Owner shall have full powers to require removal of any or all the materials brought to site by the bidder which are not in accordance with the contract specifications or do not conform in character or quality to the samples approved Owner. In case of default on the part of the bidder in removing rejected materials, the Owner shall be at liberty to have them removed by other means. The Owner shall have full powers to direct other proper materials to be substituted for rejected materials and in the event of the bidder refusing to comply. Owner may cause the same to be supplied by other means. All risks and costs which may attend upon such removal and/or substitution shall be borne by the bidder.
- 13.6 Bidder shall be responsible for procurement of all materials/ equipments etc. No delay due to non availability of any material equipment will be entertained by Owner.

14.0 Method of storing the materials

- 14.1 The bidder shall at his own cost, provide for all necessary storage on the site in specified areas for all materials such as steel, cement and such other materials which are likely to deteriorate by the action of sun, wind, rain, dampness or other natural causes due to exposure in the compounds or in stores in such a manner that all materials, tool etc. shall be duly protected from damage by weather or any other cause.
- 14.2 Materials required for the works, by the bidder be stored by the bidder only at places approved by the Owner. Storage and safe custody of materials shall be the responsibility of the bidder. All the materials including bidder's Tools & Plants brought by the bidder to the site shall become and remain the property of the Owner and shall not be removed off the site without prior written approval of the Owner/Owner. But whenever the

works are finally completed and advances, if any, in respect of such materials are fully recovered, the bidder shall at own expenses forthwith remove from the site all surplus materials supplied by him and upon such removal, the same shall revert in and become the property of the bidder.

15.0 Shuttering and Scaffolding Materials: It shall be desirable to have adequate amount of shuttering and scaffolding materials to complete the work speedily and Owner decision so as to the quantum of these desirable/ resources of the site shall be final and binding.

16.0 Completion of Work: Before finally leaving site, all the Bidders stores, plant, tools and rubbish shall be removed and the site left clean and tidy. The space allocated by Owner shall be vacated and handed over to the Owner.

17.0 Water and Electricity for Construction work : Water & Electricity as per relevant section's mentioned above

18.0 Employment of Labour

18.1 The bidder shall comply with the requirement of statutory provisions and shall be solely responsible for fulfillment of all legal obligations under Contract Labour (R&A) Act, Inter State Migrant Workmen (Registration of Employment and condition of Service Act, Payment of Wages Act., Minimum Wages Act, Workmen's Compensation Act, Factories Act, Employee's Provident Fund & Miscellaneous Provisions Act, Payment of Bonus Act, Payment of Gratuity Act, Industrial Disputes Act and all other Industrial/Labour enactments and Rules made there under as applicable from time to time. In case Owner incurs any liability towards payment of any dues, compensation, cost of any other liability of any kind whatsoever, due to non-fulfillment of statutory provisions under any industrial/labour laws by the bidder, the same shall be made good by the bidder and Owner shall have full right to recover and claim the same against the bidder from his outstanding bills or otherwise. No labour to stay at site.

18.2 The bidder will be expected to employ on the work only his regular skilled employees with experience of this particular work. The permission of the Owner must be obtained before tradesman are recruited locally for the work. This rule does not apply to unskilled labour. No female labour shall be employed in dark hours/ i.e. hours prohibited under the applicable law. No person below the age of eighteen years shall be employed at any point of time. The bidder shall pay, to each person, the wages as per minimum Wages Act of the State Government.

18.3 All traveling expenses including provision of all necessary transport to and from site, lodging allowances and other payments to the bidder's employees are his own responsibility. The hours of work on the site shall be decided by the Owner and bidder shall adhere to the same. All bidders employees shall wear safety helmet and such identifications marks as may be provided by bidder on work site and duly approved by Owner. All notices displayed on the site and any instructions issued by the Owner shall be strictly adhered to by the Bidder's and/or his sub-bidders employees. The bidder shall be required to maintain employment records as covered in relevant Acts and produce documentary evidence to the effect that he has discharged his obligations under the Employees Provident Fund Act 1952, and ESI Act, 1948 Group Insurance and other Acts for the workmen working at site.

18.4 The bidder shall comply with the provisions of the Apprentices Act 1961, and the rules and orders issued there under from time to time. If he fails to do so, his failure will be a breach of the contract and the Dean Infrastructure/Executive Engineer may in his discretion, without prejudice to any other right or remedy available in law, cancel the contract. The bidder shall also be liable for any pecuniary liability arising on account of any violation by him of the provisions of the said Act.

19.0 Working and Safety Regulations: The bidder shall observe all statutory safety and legal requirements regulations issued by Central and State Governments applicable to the work as well as any local regulations applicable to the site issued by the Owner or any other authority.

20.0 Particular attention is drawn to the following: In case of accident, the Owner shall be informed in writing forthwith and First-Aid, Hospitalization shall be provided by the Bidder. The bidder shall strictly follow regulations laid down by Govt. and State authorities in this regard and all cases are to be defended by the bidder. The Owner shall not refund any insurance claims. Bidder shall fence his plant, platforms, excavations etc. Compliance with all electricity regulations. Compliance with statutory requirements for inspection and test of all lifting appliances and

auxiliary lifting gear. Staircase, doors or gangways shall not be obstructed in any way that will interfere with means of access of escape. Where it is necessary to provide and/or store petroleum products or petroleum mixtures and explosive, the bidder shall be responsible for carrying out such provision and/or storage in accordance with the rules and regulation laid down in Petroleum Act 1934. Explosive Act 1948 and Petroleum and Carbide of Calcium Manual Published by the Chief Inspector of Explosive of India. All such storage shall have prior approvals of the Owner. In case any approval or clearance from Chief Inspector of Explosive or any statutory authorities is required, the bidder shall be responsible for obtaining the same.

The bidder shall have his own Fire Fighting Extinguishers and Equipment. The bidder shall be responsible for the provision of all safety notices safety equipments including the safety gadgets for his workmen required by both the relevant legislation and such as the Owner may deem necessary. While working at heights, safety belts and safety helmets shall necessarily be used.

21.0 Owner's and Bidder's Risks: The Owner carries the risks, which this Contract states are The Owner risks, and the Bidder carries the risk, which this Contract states are The Bidder's risks.

21.1 Owner's Risks: The Owner is responsible for the accepted risks which are :

- a. In so far as they directly affect the execution of the Works. These include war, hostilities, invasion, act of foreign enemies, rebellion, revolution, insurrection of military or usurped power, civil war, riot commotion or disorder (unless restricted to the Bidder's Employees), and contamination from any nuclear fuel or nuclear waste or radioactive toxic explosive, or
- b. A cause due solely to the design of the Works, other than the Bidder's design.

21.2 Bidder's Risks: All risks of loss or damage to physical property and of personal injury and death which arise during and in consequence of the performance of the Contract other than the accepted risks of the owner.

21.3 The Bidder shall be responsible for all injury to persons, animals or things, and for all damages to the structural and/or decorative part of property which may arise from the operations or neglect of himself or of any sub-bidder or of any of his or sub-bidder's employees whether such injury or damage arises from carelessness accident or any other causes whatsoever in any way connected with the carrying out to the Contract. This clause shall be held to include interalia any damage to buildings, whether immediately adjacent or otherwise and any damage to roads, footpaths, or ways as well as all damage caused to the buildings and the work forming the subject to this Contract by frost, rain or other inclemency of the weather. The Bidder shall indemnify the Owner and hold him harmless in respect of all and any expenses arising from any such injury or damage to persons or property as aforesaid and also in respect of any claim made in respect of injury or damage under any acts of Government or otherwise and also in respect of an award of compensation or damages consequent upon such claim. The bidder shall make good all damages of every sort mentioned in the Clause, as to deliver up the whole of the Contract works complete and perfect in every respect and so as to make good or otherwise satisfy all claims for damage to the property of third parties.

22.0 Insurance

22.1 The Bidder shall provide, in the joint names of the Owner and the Bidder, insurance cover from the Start Date to the end of the Defects Liability Period, in the amounts and deductibles stated in the Contracted Data for the following events which are due to the Bidder's risks and shall be covered under respective policies as under :

- a. Workmen Compensation Policy;
- b. Bidder's All Risk Policy;
- c. Third Party Insurance.

22.2 Policies and certificates for insurance shall be delivered by the Bidder to the Owner for the approval before the Date of Start of work i.e. dates of execution of the contract. All such insurance shall provide for compensation to be payable in the types and proportions of currencies required to rectify the loss or damage incurred.

- 22.3 If the Bidder does not provide any of the policies and certificates required, the Owner may affect the insurance which the Bidder should have provided and recover the premiums the Owner has paid from payments otherwise due to the Bidder or if no payment is due, the payment of the premiums shall be a debt due.
- 22.4 Alterations to the terms of the insurance shall not be made without the approval of the Owner.
- 22.5 Both parties shall comply with the conditions in the insurance policy.

23.0 Setting out Works: The bidder shall set out the works and responsible for the true and perfect setting out of the same and for the correctness of the positions, levels, dimensions and alignment of all parts thereof, if at any time any error shall appear during the progress of any part of works the bidder shall at his own expenses rectify such error, if called upon to the satisfaction of the Owner.

24.0 Bidder to remove all offensive matter, non-suitable material etc immediately.

- 24.1 All debris, excavated soil, filth or other matter of an offensive nature taken out of any trench, sewer, drain cesspool or other place shall not be deposited on the surface but shall be at once carted away by the bidder out of the premises/ site under intimation to concerned authorities.
- 24.2 Any material brought on site if found unsuitable shall be removed from site at once by the Bidder under intimation to the concerned authorities.

25.0 Inspections by Owner

- 25.1 The representative of the Owner at all times have free access to the works and /or to the workshops, factories or other places where materials are being prepared or constructed for the Contract and also to any place where materials are lying or from which they are being obtained. No person except the representatives of Public authorities shall be allowed on the work at any time without the written permission of the Owner. If any work is to be done at a place other than the site of the works, the Bidder shall obtain written permission of the Owner for doing so.
- 25.2 The Owner and their representatives shall have the right to test and/ or inspect the works to confirm their conformity to the contract, at all times, whenever in progress either on the site on the Bidder's premises wherever situated or any firm or company where work in connection with this contract may be in hand. All records, registers or documents relating to the works including materials used on works shall be kept open to the inspection of the Owner or his Authorized representative when so called for in writing.
- 25.3 The Bidder shall get the quality of work done inspected for material and workmanship at different stages of execution as per instructions given by the Owner or their representative time to time. Any item of work done which is found not conforming to the Contract shall be rejected by the Owner. The decision of the Owner in such cases shall be final.
- 25.4 The inspections and tests may be conducted on the premises of the Bidder or at the Project site. When carried out on the premises of the Bidder or its sub-Bidder(s), all reasonable facilities and assistance including access to drawings and production data shall be furnished to the inspectors at no charge to the Owner.
- 25.5 Should any inspected items of work fail to conform to the specifications, the Owner shall communicate them and the Bidder shall either replace them or make all alterations necessary to meet specification requirements free of cost to the Owner.
- 25.6 The Bidder shall permit the Owner/Architect to inspect the Bidder's accounts and records relating to the performance of the Bidder and to have them audited by auditors appointed by the Owner, if so required.

26.0 Covering Up/Uncovering of Works

- 26.1 No part of the works shall be covered up without the approval of Owner and the Bidder shall afford full opportunity for examination and inspection by the Owner. The bidder shall give due notice to the EIC about the work to be covered up for its measurements and examination. The EIC shall within a reasonable time attend for the purpose of examining such work, unless the EIC specifically advises the Bidder in writing of his unwillingness not to attend for such examination in which case the Bidder may proceed further with the Contract work.
- 26.2 Should the Owner consider it necessary in order to satisfy himself as to the quality of the work, the Bidder shall at anytime during the continuance of the contract pull down or cut into any part of the work and make such

opening into and to such an extent through the same, as the Engineer may direct and the Bidder shall make good the whole to the satisfaction of the Engineer, should the work prove to be faulty or in any respect not in accordance with the terms of the contract documents, the Engineer shall be at liberty to order such further removal as he may consider necessary and the whole of the expenses incurred shall be borne by the bidder. If however, the work proves to be sound and in accordance with the contract document, the actual expenses incurred in such examination will be borne by the Owner.

- 26.3 Rates charged by the Bidder for works performed under the contract shall not vary from the rates quoted by the Bidder in its bid, with the exception of any price adjustments authorized in SCC or in the Owner's request for bid validity extension, as the case may be.
- 26.4 If requested by the Owner, the Bidder shall provide the Owner with a detailed cost breakdown of any rate in the Schedule of Quantities.
- 26.5 The Owner may at any time / stage of execution demand for the Analysis of Rates for any item / items of work which in their opinion is / are abnormally high / low rates or required for the Analysis of Rates of other Publish / extra item / items. The Bidder is bound to present the same and if the Bidder is unable to present a justified Analysis of Rates for any item / items, the rate / rates for such item may be adjusted accordingly and the decision of the Owner in such cases shall be final.

27.0 Change in the order/ Extra items of work

- 27.1 The Owner may at any time, by written order given to the Bidder, make alterations in, omissions from, additions to, or substitutions for, in drawings, designs or specifications or quantities of the items of work.
- 27.2 Owner reserves to itself the right of omission of any item of work from the awarded Publish at any time / stage during the execution of work and award the same to another agency / bidder.
- 27.3 The Owner may at any time by written order given to the Bidder, increase the scope of work or include any new item of work. The Bidder shall be bound to carry out such works, the rates for which shall be arrived as below:
 - a. In the case of Extra Item(s) being the schedule item(s) (Delhi Schedule of Rates item), these shall be paid as per the schedule rate (at the time of tender) plus/minus percentage above/below quoted contract amount. Payment of Extra Item(s) in case of non-schedule item (Non-DSR item) shall be made as per the prevailing market rate.
 - b. In the case of Substituted item(s) being the schedule item(s) (Delhi Schedule of Rates item), these shall be paid as per the schedule rate (at the time of tender) plus/minus percentage above/below quoted contract amount. Payment of substitute in case of non-schedule item (Non-DSR item) shall be made as per the prevailing market rate.

28.0 Payment

- 28.1 The method and conditions of payment to be made to the Bidder under the contract shall be specified in SCC.
- 28.2 Payment shall be made promptly by the Owner within thirty (30) days of certification of the bill by the Owner.
- 28.3 All intermediate running payments to the bidder shall be regarded as payments by way of advance against the final payment and shall not preclude the requiring of bad, unsound and imperfect or unskillful work to be removed, taken away and reconstructed or re-erected.

29.0 Variations and Provisional Cost(If applicable):

- 29.1 Where work cannot be measured and valued properly, the Bidder shall be allowed day work rates on the prices prevailing when such work is carried out (unless otherwise provided in the contract):
 - a. At the rates if any inserted by the Bidder in the priced Schedule of Quantities or
 - b. If no such rates have been inserted then at the rates prevailing in the market for material and labour and at the control rates for the controlled materials including in all cases the rate for delivery of the material at the work.
- 29.2 Provided that in any case voucher specifying the time daily spent upon the work (and if required by the Owner the workman's names) and the materials used shall be delivered for verification to the Owner, or his authorized representative not later than the end of the week following that in which the work has been executed. Effect shall be given to the measurement and valuation of variations in interim Certificates and by adjustment of the total Contract Value.

30.0 Claims for Extra or for Deductions

- 30.1 The Owner shall not be responsible for the payment of any claim for extra work not included in the contract nor the Bidder shall be entitled to claim any addition to the contract sum in respect of any changes or alterations in the materials used unless the same shall have been ordered or sanctioned, as the case may be, in writing by the Owner.
- 30.2 The Bidder has to submit a monthly return by 10th of the ensuing month for any extra work which in his opinion is not covered by the contract agreement through the Owner's/ Owner's representatives and obtain a receipt from the authorized signatory of the Owner. Failing this, he shall have no right to any such claim, whatsoever may be the circumstances, later on.
- 30.3 In the event of any dispute arising either as to validity of the claim or as to the account to be paid or allowed in respect thereof, the decision of the Owner shall be final and binding on the bidder. In the meantime, the Bidder may either proceed with the work in question or suspend the same as may be determined by the Owner.
- 30.4 All extra works (those permitted by Owner) of every description shall be executed by bidder on site of work in pursuance of any of the provision of the contract, shall be measured up, and shall be paid according to actual quantities ascertained by such measurements and the prices as finalized by the Owner based on the priced schedule of quantities so that such priced schedule of quantities shall include all such operations and accessories as appear in the said schedule of prices or specification to be or shall in the opinion of the Owner the contingencies upon the works mentioned in such schedule of prices or required to make such works perfect and fit for use.
- 30.5 Provided also that if any work shall be ordered by the Owner and executed by the Bidder for the payment of which no provision in the opinion of the Owner have been made in the priced schedule of quantities or the specifications, the Owner shall fix and determine such prices for the same based on the prices appearing in the priced schedule of quantities, such allowance being made as may seem to the Owner sufficient for any difference in the character of conditions of the work. However rates for extra items shall be fixed on the basis of actual rate analysis.
- 30.6 If, it shall appear that the work has been executed with unsound, imperfect or unskilled workmanship, or with material of any imperfect or any inferior quantity or otherwise not in accordance with the contract documents the Bidder shall at his own cost rectify, reform, remove, or reconstruct the same, wither in the whole or in part, as may be directed by the EIC, whether or not the value of any such work or materials shall have been included in any payment made to the Bidder.
- 30.7 The Bidder shall remove all malba etc., wash and clean the floors and hand over the site quite clean on the completion of the work.

31.0 Delay in the Bidder's performance

- 31.1 Execution of the work and performance of the services shall be done by the Bidder in accordance with the time schedule specified by the Owner in the Notice inviting tender.
- 31.2 If, at any time during performance of the contract, the Bidder should encounter conditions impeding timely execution of the works and performance of services, the Bidder shall promptly notify the Owner in writing of the fact of the delay, its likely duration and its cause(s). As soon as possible, after receipt of the Bidder's notice, the Owner shall evaluate the situation and may, entirely at its discretion, extend the Bidder's time for performance with or without liquidated damages

32.0 Liquidated Damages: If the Bidder fails to execute any or all of the works or to perform the services within the period(s) specified in the contract, the Owner shall deduct from the contract value, as liquidated damages, a sum specified in the SCC for each week or part thereof delay until actual completion or performance, up to a maximum deduction of the percentage specified in SCC. Once the maximum is reached, the Owner may consider termination of the contract.

33.0 Termination by Default

The Owner may without prejudice to any other right or remedy, by written notice (of fifteen days) of default sent to the Bidder, terminate the contract in whole or part: a) if the Bidder fails to complete any or all of the works within the period(s) specified in the NIT or any amendment thereof, or within any extension thereof granted by the Owner, or for any cause including unsatisfactory performance or violation of the terms and conditions of the contract whatsoever or b) if the Bidder fails to perform any other obligation(s) under the contract.

In the event, the Owner terminates the contract in whole or in part, the Owner may procure, upon such terms and in such manner as it deems appropriate, works or services similar to those unexecuted and the Bidder shall be liable to the Owner for any excess costs for such similar work or services. However, the Bidder shall continue the performance of the contract to the extent not terminated.

The owner may terminate the contract bond without prejudice due to financial malpractice/ misbehavior/ verbal or physical assault/ poor quality of work etc. Further to this the bidder shall be debarred for two years for participating in any tender of IIT Roorkee.

Termination of the contract shall not relieve the agency/bidder from any of his obligation imposed by the contract with respect to the work performed by them prior to such termination.

In case of termination of the contract, IIT Roorkee reserves the right to get the work done by deploying other agencies. Cost incurred for the same will be recovered from agency's bill /PBG/pledged FDR.

For any above-mentioned cause including unsatisfactory performance or violation of the terms and conditions of the contract whatsoever, the contract is liable to be terminated and the agency is liable to be blacklisted and security deposit/ Performance Bank Guarantee submitted by the agency shall be forfeited and bank guarantee will be encashed.

34.0 Force Majeure

- 34.1 The Bidder shall not be liable for forfeiture of its performance guarantee, liquidated damages or termination by default, if and to the extent that, its delay in performance or other failure to perform its obligations under the contract is the result of an event of Force Majeure.
- 34.2 For purposes of this clause, "Force Majeure" means an unforeseeable event beyond the control of the Bidder and is not because of the Bidder's fault or negligence. Such events may include acts of the Owner either in its sovereign or contractual capacity, wars or revolutions, fires, floods, epidemics.
- 34.3 If a Force Majeure situation arises, the Bidder shall promptly notify the Owner in writing of such conditions and the cause thereof. Unless otherwise directed by the Owner in writing, the Bidder shall continue to perform its obligations under the contract as far as is reasonably practical, and shall seek all reasonable alternative means for performance not prevented by the Force Majeure event.

35.0 Termination for Insolvency: The Owner may at any time terminate the contract by giving written notice to the Bidder, if the Bidder becomes bankrupt or otherwise insolvent. In this event, termination will be without compensation to the Bidder, provided such termination will not prejudice or affect any right of action or remedy which has accrued or will accrue thereafter to the Owner.

36.0 Termination for Convenience: The Owner, by written 30 days prior notice sent to the Bidder may terminate the contract, in whole or in part, at any time for its convenience. The notice shall specify that the termination is for Owner's convenience, the extent to which performance of the Bidder under the contract is terminated, and the date upon which such termination becomes effective. The items of work that are complete and ready within (1) month after the Bidder's receipt of notice of termination shall be accepted by the Owner at the contract terms and values.

For the remaining works, the Owner may elect;

- a) to have any portion completed at the contract terms and value and/or
- b) to cancel the remainder and pay to the Bidder an amount, finalized by the Owner, for partially completed works and for materials and parts previously procured by the Bidder.

37.0 Resolution of Disputes

37.1 The Owner and the Bidder shall make every effort to resolve amicably by direct informal negotiations any disagreement or dispute arising between them under or in connection with the contract. If, after thirty (30) days from the commencement of such informal negotiations, the Owner and the Bidder have been unable to resolve amicably a contract dispute, either party may require that the dispute be referred for resolutions to the formal mechanisms specified in the SCC. These mechanisms may include but are not limited to, Arbitration in accordance with rules of Arbitration Act and award made in pursuance thereof shall be binding on both the parties.

37.2 All disputes should be under the Jurisdiction of civil court Roorkee.

- 38.0 Governing language:** The contract shall be written in Hindi or English language. All correspondence and other documents pertaining to the contract that are exchanged by the parties shall be written in the same language.
- 39.0 Governing law:** The contract shall be governed by the laws of The Union of India for the time being in force. All disputes are subject to jurisdiction of courts at Roorkee or Honorable High Court Utrakhand at Nainital.
- 40.0 Notices:** Any notice given by one party to the other pursuant to this contract shall be sent to other party in writing by e-mail or letter and confirmed in writing to the other party's address specified in SCC. A notice shall be effective on the date on which it is delivered, or on the notice's effective date, whichever is later.
- 41.0 Discoveries:** Anything of historical or other interest or of significant value unexpectedly discovered on the Site is the property of the Owner. The Bidder is to notify the Owner of such discoveries and carry out the Owner's instructions for dealing with them.
- 42.0 Dismissals of workmen:** The bidder on request from the Owner, immediately dismiss from the works any person employed by him who may be found in the opinion of the client to be unsuitable or incompetent or who has shown misconduct.
- 43.0 Working Hours:** Normal working hours shall be from 08:45 a.m. to 05:30 p.m. No construction work of important structural nature shall be carried out on Sundays, Holidays and during nights. However, working hours can be extended in case of urgency with prior approval of IIT Roorkee.

B. TIME CONTROL

44.0 Program

- 44.1 Within the time stated in the Contract Data the Bidder shall submit to the Owner for approval a Program showing the general methods, arrangements, order, and timing for all the activities in the works, along with weekly cash flow forecast.
An update of the Program shall be a programme showing the actual progress achieved on each activity and the effect of the progress achieved on the timing of the remaining work including any changes to the sequence of the activities.
- 44.2 The Bidder shall submit to the Owner, for approval, an updated Program at intervals no longer than the period as stated in the clause no. 7.1. If the Bidder does not submit an updated Program within this period, the Owner may withhold the amount stated in the Contract Data from the next payment certificate and continue to withhold this amount until the next payment after the date on which the overdue program has been submitted.
- 44.3 The Owner's/Owner's approval of the Program shall not alter the Bidder's obligations. The Bidder may revise the Program and submit it to the Owner again at any time. A revised Program is to show the effect of Variations at any stage of work, Owner award any item/part of item of work to bidder's workman/ external agency, if in their opinion, the progress of work is suffering because of that. The work done will be added to the Bidder's bill and the amount paid for the job will be deducted from the Bidder's account.

45.0 Delay and Extension of time

If in the opinion of the Owner the work be delayed

- a) by force majeure or
- b) by reason of any exceptionally inclement weather or
- c) by reason of proceedings taken or threatened by or disputes with adjoining or neighboring owners or public authorities or
- d) by delays of other bidder or Tradesmen engaged by the Owner or the Owner and the works not referred to in the Schedule of Quantities and/or specification or
- e) by reasons of Owner's instruction or
- f) by reason of civil commotion, local combination of workmen or strike or lockout affecting any of the building trades or
- g) in consequence of the bidder not having received in due time necessary instructions from the Owner for which he shall have specially applied in writing or

- h) from other cause which the Owner may certify as beyond the control of the bidder or
- i) by reason of nonpayment of interim certificate at specified time, the Owner shall grant for approval by the Owner a fair and reasonable extension of time for completion of the Contract. In case of strike or lockout the bidder shall as soon as may be given written notice thereof to the Owner, but the bidder shall nevertheless constantly use his endeavours to prevent delay and shall do all that may reasonably be required to the satisfaction of Owner to proceed with the work.

C. QUALITY CONTROL

46.0 Identifying Defects: The Owner shall check the Bidder's work and notify the Bidder of any Defects that are found. Such checking shall not affect the Bidder's responsibilities. The Owner may instruct the Bidder to search for a Defect and to uncover and test any work that the Owner considers may have a Defect.

47.0 Correction of Defects

47.1 The Owner shall give notice to the Bidder of any Defects before the end of Defects Liability Period, which begins at Completion and is defined in the Contract Data. The Defects Liability period shall be extended for as long as Defects remain to be corrected.

47.2 Every time notice of Defect is given, the Bidder shall correct the notified Defect within the length of time specified by the Owner's notice.

48.0 Uncorrected Defects: If the Bidder has not corrected a defect within the time specified in the Owner's notice. In case, it is felt by the Owner that undue delay is being done by the bidder, the same will be got done by the Owner at the risk and cost of the contractor.

D. COST CONTROL

49.0 Schedule of Quantities

49.1 The Schedule of Quantities shall contain items for the construction work, installation, testing, and commissioning work to be done by the Bidder.

49.2 The Schedule of Quantities is used to calculate the Contract Price. The Bidder is paid for the quantity of the work done at the rate in the priced Schedule of Quantities for each item.

50.0 Variations: All variations in the program pursuant to clause no. 7.0 of GCC shall be included in the updated program produced by the Bidder.

51.0 Payments for Variations

51.1 The Bidder shall provide the Owner with a quotation (with breakdown of unit rates) for carrying out the Variation when requested to do so by the Owner. The Owner shall assess and finalize the quotation, which shall be given within seven days of the request or within any longer period stated by the Owner and before the Variation is ordered.

51.2 If the Bidder's quotation is unreasonable, the Owner may order the Variation and make a change to the Contract Price which shall be based on Owner's own forecast of the effects of the Variation on the Bidder's costs.

51.3 If the Owner decides that the urgency of varying the work would prevent a quotation being given and considered without delaying the work, no quotation shall be given and shall be treated as a Variation.

51.4 The Bidder shall not be entitled to additional payment for costs, which could have been avoided by giving early warning.

E: FINISHING THE CONTRACT

- 52.0 Completion Certificate:** The Bidder shall request the Owner to issue a Certificate of Completion of the Works will do so upon deciding that the Work is completed.
- 53.0 Taking Over:** The Owner shall take over the Site and the Works within seven days of the Owner issuing a certificate of Completion. Before handing over the site, the bidder must obtain a site clearance certificate from the Owner.
- 54.0 Final Account:** The Bidder shall supply to the Owner a detailed account of the total amount that the Bidder considers payable under the Contract before the end of the Defects Liability Period. The owner shall issue a Defect Liability Certificate and certify any final payment that is due to the Bidder within 5-6 days of receiving the Bidder's account if it is correct and complete. If it is not, the Owner shall issue within 5-6 days a schedule that states the scope of the corrections or additions that are necessary. If the Final Account is still unsatisfactory after it has been resubmitted, the Owner shall decide on the amount payable to the Bidder and issue a payment certificate within 5-6 days of receiving the Bidder's revised account.

SPECIAL CONDITIONS OF CONTRACT (SCC)

The following Special Conditions of Contract are supplementary to the General Conditions of Contract. Whenever there is a conflict, the provisions herein shall prevail over those in the General Conditions of Contract. The corresponding clause number of the General Conditions of Contract is indicated in parentheses.

1. Definition (SCC clause 1.0)

- a) Owner means: IIT Roorkee.
- b) Site means the project site situated in IIT Roorkee Main Campus & Saharanpur Campus.

2. (i) Security Deposit: As per Critical Data Sheet.

- (ii) Release of Security Deposit: Security Deposit will be refunded by the Owner after completion of Defect Liability Period i.e. 12 months from date of work completion (in case of work).

3. Performance Guarantee: As per Critical Data Sheet. Performance guarantee shall be valid for a period of 60 days after completion.

4. Warranty (Defective Liability Period):

(a) Minimum warranty period of complete system will be **one year**. However, for outsourcing services an undertaking for statutory payment liability shall be taken from the Contractor. Equipment warranty certificate as per OEM will be submitted to the department.

(b) During warranty period, all elements of the system which fail due to manufacturing defects or operational wear & tear shall be replaced / repaired by the bidder without any charges. In case it is felt by the department that undue delay is being caused by the bidder in doing this, the same will be got done by the department at the risk and cost of the bidder. The decision of Dean Infrastructure in this regard shall be final.

(c) The bidder shall warranty the performance of the system. If it is not achieved, the necessary additions/modifications shall be done by the bidder without charging any extra price. However, the owner reserves the right to have this job done by other manufacturers if the bidder does not get the work done within 15 days of issuing the notice to the bidder. The cost for the same shall be borne by the bidder.

5. Payment:

4.1 a) No advance payment shall be made.

b) **For Part-A:** Approximately 70% on successful delivery of material at site in good condition, approximately 20% on installation and approximately 10% after testing & commissioning.

For Part-B: Payment shall be made quarterly, after successful completion of each quarter service.

c) Part of the payment can be withheld by the department.

5.2 Payment shall not be released against 1st R/A bill until submission of following documents by bidder to the Owner:

- a) Measurement Book (MB).
- b) GST Invoice with revenue stamp.
- c) EPF & ESI deposit proof (of one month prior to the month of invoice).
- a) Insurance – Bidder's All Risk (CAR) Policy, Workmen compensation policy and Third-Party Liability Insurance.

5.2.1 Basis of Payment in RA bills

Payment in RA bills shall be based on quantity of work/ service/ supply executed at site (as per the item of work/ service/ supply) & verified by Owner as per the item rate in work orders. Owner is authorized to allow payment for part rate/reduced rate/full rate for any item(s) in the Schedule of Quantity. Further owner is authorized to allow different part rates/ reduced rate for different item(s).

5.2.2 Disallowance of payment

If payment has been made in RA bill for any item of work but later some defect is noticed, Owner/Architect is authorized to disallow the payment in the subsequent bills till rectification of the work.

5.1 Final bill

The final bill complete in all respect shall be submitted by the bidder within 60 days from the date of completion of work. The total quantity may vary as per actual work/ service/ supply execution/site requirement/and user suggested changes during execution.

The bill should be accompanied with the following documents.

- a) Work completion certificate.
- b) Site clearance status (only for works).
- c) Indemnity certificate towards labour payment and all statutory payments.
- d) Certificate of test on materials etc. (if applicable/ if conducted).
- e) Certificate of measurement sheets.
- f) Original quality control record (if applicable), measurement records and any other joint site records maintain at site (if applicable). No claim shall be entertained after receipt of final bill.
- g) Warranty certificate (if applicable).

Settlement of final bill shall be made subject to deduction of all dues payable by bidder, settlement of all disputes and furnishing of all required documents/clarifications and grant of extension of time, if any, by Owner's competent authority.

1. Liquidated Damages

The quantum of work with stipulated time (as per discretion of EIC) will be communicated to the firm via email, hard copy or telephonically. In case of delay/partial completion, 0.5% per week of balance / unattended work subject to a maximum of 5% (Five percent) of the Contract value from the stipulated date of completion.

2. Resolution of Disputes

In case the parties don't agree to the advice of owner, then the Director, IIT Roorkee shall appoint a sole arbitrator within 30 days of receipt of request forthwith. The arbitration shall be governed by Arbitration and Reconciliation Act 1996.

3. Notices

For the purpose of all notices, the following shall be the address of the Owner and the Bidder.

Owner: Dean Infrastructure,
Institute Works Department,
Indian Institute of Technology
Roorkee

Bidder: _____

(To be filled in at the time of Signing of the Contract)

4. Resolution of Disputes & Arbitration

Except where otherwise provided in the contract all questions and disputes relating to the meaning of the specifications, design, drawings and instructions here in before mentioned and as to the quality of workmanship or materials used on the work or as to any other question, claim, right, matter or thing whatsoever in any way arising out of or relating to the contract, designs, drawings, specifications, estimates, instructions, orders or these conditions or otherwise concerning the works or the execution or failure to execute the same whether arising during the progress of the work or after the cancellation, terminations, completion or abandonment thereof shall be dealt with as mentioned hereinafter.

If the bidder considers any work demanded of him to be outside the requirements of the contract or disputes any drawings, record or decision given in writing in connection with or arising out of the contract or carrying out of the work, he shall promptly within 15 days request the Owner in writing for written instruction or decision.

If the Bidder is dissatisfied with this decision, the Bidder shall within a period of 30 days from receipt of the decision, give written notice to the IIT Roorkee for appointment of Arbitrator failing which the said decision shall be final binding and conclusive and not referable to adjudication by the Arbitrator.

Except where the decision has become final, binding and conclusive in terms of Sub Para (i) above disputes or difference shall be referred for adjudication through arbitration by a sole arbitrator appointed by The Director, IIT Roorkee. If reason whatsoever another sole arbitrator shall be appointed in the manner aforesaid. Such person shall be entitled to proceed with the reference from the stage at which it was left by his predecessor. It is a terms of this contract that the party invoking arbitration shall give a list of disputes with amounts claimed in respect of each dispute along with the notice for appointment of arbitrator. It is also a term of this contract that no person other than a person appointed by such IIT Roorkee as aforesaid should act as arbitrator and if for any reason that is not possible, the matter shall not be referred to arbitration at all.

It is also a term of this contract that if the contractor does not make any demand for appointment of arbitrator in respect of any claims in writing as aforesaid within 30 days of receiving the intimation from the Owner that the final bill is ready for payment, the claim of the bidder shall be deemed to have been waived and absolutely barred and IIT Roorkee shall be discharged and released of all liabilities under the contract in respect of these claims. The arbitration shall be conducted in accordance with the provisions of the Arbitration and Conciliation Act, 1996 (26 of 1996) or any statutory modifications or reenactment thereof and the rules made there under and for the time being in force shall apply to the arbitration proceedings under this clause.

5. Protection of environment

8.1 The Bidder shall take all reasonable steps to protect the environment on and off the Site and to avoid damage or nuisance to persons or to property of the public or others resulting from pollution, noise or other causes arising as a consequence of his methods of operation.

8.2 During continuance of the contract, the Bidder and his sub-bidders shall at all times abide by all existing enactment on environmental protection and rules made there under, regulations, notifications and bye-law of the State or Central Government, or local authorities and any other law, by-law, regulations that may be passed or notification that may be issued in this respect in future by the State or Central Government or the local authority.

8.3 Salient features of some of the major laws that are applicable are given below:

The Water (Prevention and Control of Pollution) Act, 1974 This provides for the prevention and control of water pollution and the maintaining and restoring of wholesomeness of water. 'Pollution' means such contamination of water or alteration of the physical, chemical or biological properties of water or such discharge of any sewage or trade effluent or of any other liquid, gaseous or solid substance into water (whether directly or indirectly) as may, or is likely to create a nuisance or render such water harmful or injurious to public health or safety, or to domestic, commercial, industrial agricultural or other legitimate uses, or to the life and health of animals or plants or of aquatic organisms.

The Air (Prevention and Control of Pollution) Act, 1981, This provides for prevention, control and abatement of air pollution, 'Air Pollution' means the presence in the atmosphere of any air pollutant', which means any solid, liquid or gaseous substance (including noise) present in the atmosphere in such concentration as may be or tend to be injurious to human beings or other living creatures or plants or property or environment.

The Environment (Prevention and Control of Pollution) Act, 1986 This provides for the protection and improvement of environment and for matters connected to herewith, and the prevention of hazards to human beings. Other living creatures, plants and property, 'Environment' includes water, air and land and the interrelationship which exists among and between water, air and land, and human beings, other living creatures, plants, micro-organism and property.

The Public Liability Insurance Act 1991. This provides for public liability insurance for the purpose of providing immediate relief to the persons affected by accident occurring while handling hazardous substance means any substance or preparation which is defined as hazardous substance under the Environment (Protection) Act 1986, and exceeding such quantity as may be specified by notification by the Central Government.

6. Specifications to be followed for execution for execution of works are:

For Civil Works: CPWD Specifications 2009 Vol. 1 and Vol. 2 with up to date correction slips. (Hereinafter called CPWD specifications also) and Specification mentioned in This Publish document for each project.

For Electrical Works: CPWD General Specifications for Electrical Works, Part-I (Internal) 2023 and CPWD General Specifications for Electrical Works, Part-I (External) 2023 and Specification mentioned in this bid document for each project.

7. If the bidder wants to offer any unconditional rebates on their offer that should be clearly mentioned.
8. In case any information furnished by the bidder is found to be false / forged / incorrect at any stage, their bid shall be rejected, and the bidder shall not be allowed to participate in the re-bidding process of the work.
9. **Clarification of Bids/ Shortfall Documents:** IIT Roorkee may, at its discretion, ask the bidder for clarifications / shortfall documents related to his bid. The request for clarification shall be given in writing. Depending on the reply of the bidder, his bid shall be ignored or considered further.
10. Tender will be awarded on overall L1 basis (including BoQ1, BoQ2, BoQ3 etc.).
11. **Abnormally High and Low Bids:**
 - a) Tender evaluation committee (TEC) will observe the rates and seek justifications if that are abnormally high/low. Threshold value over which the rates would be judged high/low shall be decided by the TEC looking into the nature of work and their specification on case to case basis
 - b) If required necessary for high bids negotiation will be done with the approval of the Competent Authority. However, if the rates will be found abnormally low additional security shall be got deposited as per the following formula:
 - i) Upto 30% less than the estimated cost : nil
 - ii) Above 30% and less than upto 50% : 20%
 - iii) Above 50% and less than upto 70% : 40%
12. The bidder who has two ongoing General Repair & Maintenance/Routine works in-hand for electrical works and three ongoing General Repair & Maintenance/Routine works for civil works shall not be allowed to participate in another fresh tender of General Repair & Maintenance/Routine works.
13. Working/Running Contractor who have completed their work upto/ above the awarded value of contract bond duly verified by the Engineer-in-charge shall be considered as work completed and such contractors shall be allowed to participate in tenders.
14. Only 'Class-I local supplier' and 'Class-II local supplier', as defined in the Public Procurement (Preference to Make in India), Order 2017 shall be eligible to bid in the tender. For more details please refer: Order No.: P-45021/2/2017-PP (BE-II), DPIIT, Ministry of Commerce and Industry issued Dated: 16th Sept. 2020. Self- certificate has to be provided in this regard that the item offered meets the local content requirement for 'Class-I local supplier' & 'Class-II local supplier' (as per Annexure-I).
15. Estimate is based on DSR-2022 (E&M) + DSR 2021(Civil) + Non scheduled rates with 18% GST and 1% BOCWW Cess.
16. In case the GST rate is changed by the GOI then the item rate in the estimate shall be changed on pro-rata basis.

Undertaking

(On Non-Judicial stamp paper of Rs. 100/-)

Name of the address of the bidder:

NIT No.....

Name of the work:

Due Date:

I/We have read and examined the Tender document for the work. I/We hereby submit bid for the execution of the work specified for the Institute within the time specified in NIT of quantities and in accordance with the specifications, designs, drawing and instructions in writing referred to the conditions of contract and with such materials as are provided for, by, and in respect of accordance with such conditions so far as applicable.

I/We agree to keep the Bid open for ninety (90) days from the due date of its opening and not to make any modification in its terms and conditions.

Earnest Money as mentioned in the critical data sheet is hereby forwarded in Bankers' Cheque / Demand Draft / Fixed Deposit Receipt issued by scheduled bank. If I/We, fail to furnish the prescribed performance guarantee within prescribed period. I/We agree that the Institute has to right to forfeit the said earnest money absolutely. Further, if I/We fail to commence work as specified, I/We agree that the Institute has to right to forfeit the said performance guarantee absolutely. The said performance guarantee shall be a guarantee to execute all the works referred to in the Tender documents upon the terms and conditions contained or referred to those in excess of that limit at the rates to be determined in accordance with the provision contained in NIT. Further, I/We agree that in case of forfeiture of Earnest Money or Performance Guarantee as aforesaid, I/We shall be debarred for participation in the re-Tendering process of the work.

I/We undertake and confirm that eligible similar work(s) has/have not been got executed through another bidder on back to back basis. Further that, if such a violation comes to the notice of owner, then I/we shall be debarred for tendering in IWD, IIT Roorkee in future forever. Also, if such a violation comes to the notice of owner before date of start of work, the Engineer-in-Charge shall be free to forfeit the entire amount of Earnest Money Deposit/Performance Guarantee.

I/We hereby declare that I/We shall treat the tender documents drawings and other records connected with the work as secret/confidential documents and shall not communicate information/derived there from to any person other than a person to whom I/We am/are authorized to communicate the same or use the information in any manner prejudicial to the safety of the State.

I/We hereby declare that I/We have no near relative connection by marriage to any staff of the Institute.

The information given in the tender form is correct and best of my knowledge.

Dated:

Signature of Bidder

Witness:

Postal Address

Occupation:

PERFORMANCE GUARANTEE BOND

In consideration of the Indian Institute of Technology Roorkee having agreed under the terms and conditions of agreement No..... dated..... made between And.....(hereinafter called "the contractor(s)")..... for the work.....(hereinafter called "the said agreement") having agreed to production of a irrevocable Bank Guarantee for..... (Rupees.....only) as a security/guarantee from the contractor(s) for compliance of his obligations in accordance with the terms and conditions in the said agreement,

1. We.....(hereinafter referred to as "the Bank") hereby undertake to pay to IIT Roorkee (Indicate the name of the bank) an amount not exceeding Rs..... (.....only) on demand by the Indian Institute of Technology Roorkee.

2. Wedo hereby undertake to pay the amounts due..... and payable (Indicate the name of the Bank) under this Guarantee without any demur, merely on a demand from the Indian Institute of Technology Roorkee stating that the amount claimed is required to meet the recoveries due or likely to be due from the said contractor(s). Any such demand made on the bank shall be conclusive as regards the amount due and payable by the bank under this guarantee. However, our liability under this guarantee shall be restricted to an amount not exceeding (Rupees.....only).

3. We, the said bank further undertakes to pay to the Institute any money so demanded notwithstanding any dispute or disputes raised by the contractor(s) in any suit or proceeding pending before any court or tribunal relating thereto, our liability under this present being absolute and unequivocal.

The payment so made by us under this bond shall be a valid discharge of our liability for payment there under and the contractor(s) shall have no claim against us for making such payment.

4. Wefurther agree that the guarantee herein contained shall (Indicate the name of the Bank) remain in full force and effect during the period that would be taken for performance of the said agreement, and it shall continue to be enforceable till all the dues of the Indian Institute of Technology Roorkee under or by virtue of the said agreement have been fully paid and its claims satisfied or discharged or till Engineer-in-charge on behalf of the Institute certified that the terms and conditions of the said agreement have been fully and properly carried out by the said contractor(s) and accordingly discharges this guarantee.

5. We(indicate the name of bank) further agree with the Indian Institute of Technology Roorkee that Indian Institute of Technology Roorkee shall have the fullest liberty without our consent and without effecting in any manner our obligations hereunder to vary any of the terms and conditions of the said agreement or to extend time of performance by the said contractor(s) from time to time or to postpone for any time or from time to time any of the powers exercisable by the Indian Institute of Technology Roorkee against the said contractor(s) and to forebear or enforce any of the terms and conditions relating to the said agreement and we shall not be relieved from our liability by reason of any such variation, or extension being granted to the said contractor(s) or for any forbearance, act of omission on the part of the Institute or any indulgence by the Indian Institute of Technology Roorkee to the said contractor(s) or by any such matter or thing whatsoever which under the law relating to sureties would, but for this provision, have effect of so relieving us.

6. This guarantee will not be discharged due to the change in the constitution of the Bank or the contractor(s).

7. We (Indicate the name of the Bank) lastly undertake not to revoke this guarantee except with the previous consent of the Indian Institute of Technology Roorkee in writing.

8. This guarantee shall be valid up to..... unless extended on demand by Indian Institute of Technology Roorkee. Notwithstanding anything mentioned above, our liability against this guarantee is restricted to(Rupees.....only)and unless a claim in writing is lodged with us within six months of the date of expiry or the extended date of expiry of this guarantee all our liabilities under this guarantee shall stand discharged. Dated theday of..... for (Indicate the name of the Bank).

Annexure-I

(to be submitted by the vendor/firm on its official letter head)

Self-Certificate for Local Content

Tender No:

Dated

We hereby certify that the items quoted by us against above mentioned tender no. has the local content as per below:

Local Content (in %):

Local Supplier Class:

The details of the Make in India items/parts used in the quoted products is/are as under:

- 1.
- 2.
- 3.

The details of the location(s) at which the local value addition made/manufactured is/are as under:

- 1.
- 2.
- 3.

We also understand, false declarations will be in breach of the code of integrity under rule 175(1)(i)(h) of the General Financial Rules for which a bidder or its successors can be debarred for up to two years as per Rule 151(iii) of the General Financial Rules along with such other actions as may be permissible under law.

Signature:

Name:

Designation:

Seal of the Firm/Organization:

Annexure-II

PERFORMA FOR DIRECT PAYMENT/ TRANSFER TO BANK ACCOUNT BY IIT ROORKEE

S. No.	Particulars	Information
1	Firm (Beneficiary) Name	
2	Address	
3	Complete Bank Account No. of the Firm (Beneficiary) (In case of change in Bank Account vendor write to Account Office)	
4	Bank Name	
5	Branch Address	
6	IFSC Code No.	
7	Permanent Account No.	
8	Mobile No. (for SMS)	
9	Email ID (For Information)	
10	Enrolment No. (for student)	

We undertake that all the information provided above is correct and IIT Roorkee will not be responsible in case of any error on the part of firm.

Verification by Bank (one time only) Information given at 1,4,5,6&7 verified by Bank Seal and Signature of the Bank	Seal and Signature of the Firm
---	--------------------------------

Site Conditions

The bidders are strictly advised to visit both sites before quoting. The tentative dimensions of lift shafts are as below:

Location	No. of Lifts	No. of Stops	Pit Depth (in mm)	Shaft Width (in mm)	Shaft Depth (in mm)	Head Room (in mm)
Hill View Apartment Block A & B	2	8	1770	2440	1895	5700
Hill View Apartment Block C & D	2	8	1590	2480	1870	5660
Radhakrishnan Bhawan front side	2	8	1580	2500	1880	4610
Radhakrishnan Bhawan right side	2	8	1690	2490	1890	4750
Radhakrishnan Bhawan left side	2	8	1580	2540	1900	4610

Note: The above dimensions are tentative and not exact. Bidders should measure before quoting.

Scope of Work

For Part-A: Supply, Installation Testing & Commissioning (SITC)

The Work involves removal of old 04 no. of lifts at Hill view Apartment and 06 no. of lifts at Radhakrishnan Bhawan of IIT Roorkee. After removal of old lifts, installation of new passenger lift and service lift shall be done in the existing lift shafts. If any minor strengthening of existing lift shaft is required then the same shall be done by the successful bidder during execution. Both the buildings i.e. Hill view Apartment and Radhakrishnan Bhawan are occupied by residents, hence due care and safety measures should be adopted during work execution. During execution, it should be ensured that at least one working lift is available at each tower during the period of the project.

TECHNICAL SPECIFICATIONS

1. The OEM should have an established service center operational since last 3 years within 75 Km road distance from IIT Roorkee (main campus) at the time of submission of bid.
2. The OEM shall provide lift monitoring system which will enable the user to monitor the lifts from remote. This shall include door status (open/ close), floor number, real-time notifications, error history.

Passenger Lift:

The lift shall be made with the following cage dimensions of lift recommended for passenger lift by Bureau of Indian Standards.

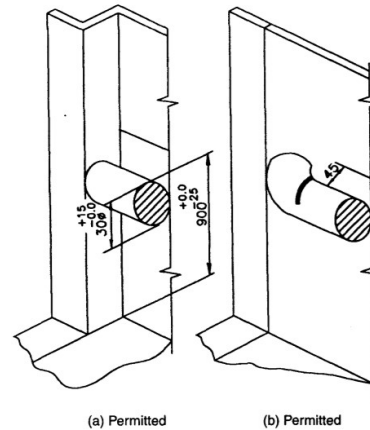
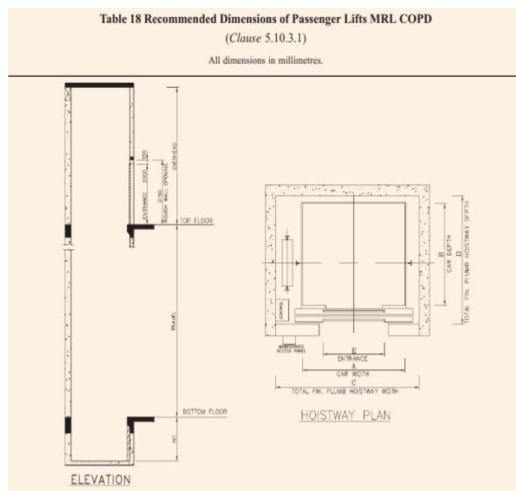

Load		Door	Car Inside (min.)		Lift Shaft		Entrance (min.)	Door Height (min.)	Pit Depth (min.)
Person	Kg		A	B	C	D			
20	1360	COAD	1800	1700	2700 (or as per existing structure and site condition)	2300 (or as per existing structure and site condition)	1100	2000	1800 (or as per existing structure and site condition)
15	1020	COAD	1600	1550	2550 (or as per existing structure and site condition)	2050 (or as per existing structure and site condition)	1000	2000	1800 (or as per existing structure and site condition)
13	884	COAD	1600	1400	2550 (or as per existing structure and site condition)	1950 (or as per existing structure and site condition)	1000	2000	1800 (or as per existing structure and site condition)

08	544	COAD	1300	1100	2150(or as per existing structure and site condition)	1800 (or as per existing structure and site condition)	800	2000	1600 (or as per existing structure and site condition)
		TLAD					900		
05	340	COAD	850	1000	1800 (or as per existing structure and site condition)	1650 (or as per existing structure and site condition)	700	2000	1600 (or as per existing structure and site condition)
		TLAD					700		

Note: All dimensions are in mm.

*Normal range for Car Height is 2100 mm to 2400 mm.

COAD: Centre Opening Automatic Door.

TLAD: Telescopic Automatic Door.

1. **Pit:** Pit shall be soundly constructed and maintained in a dry (water proofed) and clean condition. The floor of the pit shall be able to support beneath the car buffer supports, force in Newton, equal to 4 times the static load being imposed by the mass of fully loaded car. The floor of the pit shall be able to support beneath the counterweight buffer support, force in Newton, equal to 4 times the static load being imposed by the mass of the counterweight. Pit ladder shall be provided in case pit depth is greater than 1300 mm below the lowest landing sill.
2. **Main Switches:** For each lift, a main switch capable of breaking the supply to the lift on all the live conductors shall be provided. This switch shall be capable of interrupting the highest current involved in normal conditions of use of the lift. This switch shall not cut the circuits feeding the following:
 - a) Car lighting and ventilation.
 - b) Socket outlet on the car roof.
 - c) Lighting of machinery spaces.
 - d) Socket outlet in the machinery and pulley spaces and in the pit.
 - e) Lighting of the lift well including pit.
 - f) Alarm device.
 - g) Automatic rescue device.
3. **Emergency signal and telephone:** The lift car shall be provided with an emergency signal that is operative from the lift car and audible outside the lift well and with a telephone.
4. All three sides of wall of the car, a handrail shall be installed. The gripping of this handrail shall have a minimum circumscribed diameter of 30 mm and a maximum of 45 mm. The free space between the wall and the gripping part shall be at least 45 mm. The height of the top edge of the gripping part shall be within 900 mm+ 0/-25 mm from the finished car floor level. The handrail may be interrupted where the car operating panel is located in order to avoid obstructing buttons or controls. If the end of a handrail directly faces a doorway it shall be returned to the wall.
5. The lift shall have VVVF motor drive. Under normal operation the leveling accuracy of the lift car shall be ± 12 mm.
6. The bottom run-by for car and counter weights shall not be less than 150mm.
7. Height from floor level to the centre line of any button shall be between 900 mm and 1100 mm.
8. Colour of any face plate of a landing push button shall be contrasted to its surrounds.
9. Distance between the active parts of two floor buttons shall be not less than 10 mm.
10. Centre line of alarm and door open buttons shall be located from the floor at 900mm. This applies even to the door closing button.
11. Highest floor button shall be located at not more than 1200 mm above the floor. When possible, the highest button should be not more than 1100 mm from the floor.
12. **Landing Signals:** Where, prior to entering the car, the control system may establish the next direction of travel (collective control) the following shall be provided:
 - a) Two illuminated indicator arrows giving advance information on the next departure direction of the car (only one at the terminal landings) placed above or near the doors in a visible position, to indicate the direction in which the car will subsequently move. Landing indicator arrows shall be located between 1.80 m and 2.50 m above the floor. The height of arrows shall be 40 mm to 70 mm or as per OEM.
 - b) An audible signal shall accompany the lighting of the arrows. The audible signal in local language(s) shall have a sound level of between 35 dBA and 55 dBA adjustable to suit the site conditions or as per OEM.

13. A car position signal shall be located with or above the car operating panel. The centre line of the indicator shall be positioned between 1.60 m and 1.80 m from the car floor.
The height of the floor number shall be between 25 mm and 60 mm and have a contrasted colour to its surround or as per OEM.
14. When the car stops, a voice shall indicate, in the local language(s) the car position. The sound level of the information shall be adjustable between 35 dBA and 55 dBA adjusted to suit the site conditions.
15. Battery operated/ back up emergency light, alarm and intercom shall be provided.
16. **Overload Prevention Device:** The lift car shall not start when the car is overloaded. The lift operation shall resume only upon removal of the overload.
17. Lift car doors and landing doors shall be of the horizontally sliding type, power operated and automatically controlled.
18. An audible signal shall be provided to signify the closing of the doors to alert persons.
19. All lift control buttons shall have a minimum dimension of 20 mm.
20. Braille and tactile markings shall be placed either on or to the left of the control buttons.
21. Such Braille and tactile markings shall be in Arabic numerals and/or symbols. Tactile markings shall have a minimum dimension of 15 mm high and be raised 1 mm minimum.
22. The tactile marking of the push buttons for the main entrance floor shall be identified with a symbol in a star shape.
23. The emergency alarm push button shall be in a tactile bell shape.
24. An emergency alarm push button together with a buzzer, an indication light for acknowledgement and an intercom shall be provided in each lift car and be connected to the building management office or the caretaker's office.
25. Management office or the caretaker's office shall be equipped with a buzzer, indication light(s) (one for each lift) and an intercom connected to the lift car(s). The indication light for acknowledgement shall be in the form of a blinking light adjacent to the intercom speaker and a notice "When light blinks, it indicates your emergency call has already been received. Please be patient and wait for the rescue." In English and Hindi shall be provided next to the blinking light.
26. This system shall be powered by an emergency electricity supply system in the event of power failure.

Annexure-C

Basic Specification for Passenger Lift			
S. No.	Features	Technical Detail	Offered by the Bidder
1	Number of passengers	20/15/13/8/5 Passenger	
2	Rated speed (m/sec)	1-1.5 M/Sec.	
3	Rated capacity (kg)	As per above table	
4	Entrance	As per above table	
5	Interior	Brush finish / Hairline finish Stainless Steel	
6	Flooring	Chequered Flooring	
7	Light & Fan	LED light/ 300mm with grill	
8	Hall position indicators and buttons	Segment LED Indicators, Tactile button along with additional brail inscriptions	
9	Floor	As per site.	
10	Three side Handrail system	Three side SS Hand railing.	
11	Travel	As per site.	
12	Stops & Opening	As per site.	
13	Ventilation	As per manufacturer	
14	Operation	Microprocessor based Simplex Collective Selective Control with/without Attendant.	
15	Power Supply	415 Volts \pm 10%, 3 Phase, 50 Hz AC systems.	
16	Controller type	V3F (Variable Voltage Variable Frequency)	
17	Type of Machine	Gearless MRL	
18	Car Enclosure	Stainless steel scratches proof (Moon Rock / Honeycomb / Hairline Finish) on all sides.	
19	Car door enclosure	Glass doors SS frame & SS jamb	
20	Landing door enclosure	Glass doors SS frame & SS jamb	
21	Indicators (Car Landing)	Digital Direction & Position Indicator	
22	Type of Doors	Car: Auto Telescopic / Centre Opening Landing doors: Auto Telescopic / Centre Opening	
23	Construction type	Machine Room Less	
24	Emergency Car Lighting	Car lighting which turns on immediately when power fails, providing a minimum level of lighting within the car.	
25	Fire Emergency Return	Upon activation of a key switch or a building's fire alarm, all calls are canceled, all cars immediately return to a specified evacuation floor and the doors open to facilitate the safe evacuation of passengers.	
26	Emergency Landing Device (Automatic rescue Device)	Upon power failure, a car equipped with this function automatically moves and stops at the nearest floor using a rechargeable battery, and the doors open to facilitate the safe evacuation of passengers. Dry type Battery (Maintenance Free) should be used for power backup.	
27	Automatic Door Speed Control	Door load on each floor, which can depend on the type of hall doors, is monitored to adjust the door speed, thereby making the door speed consistent throughout all floors.	
29	Door Load Detector	When excessive door load has been detected while opening or closing, the doors Door Load Detector immediately reverse.	
30	Door Nudging Feature — With Buzzer	A buzzer sounds and the doors slowly close when they have remained open for longer than the preset period.	
31	Multi-beam Door Sensor	Multiple infrared-light beams cover at least 2/3 of the door height of the doors to detect passengers or objects as the doors close.	
32	Reopen with Hall Button	Closing doors can be reopened by pressing the hall button corresponding to the traveling direction of the car.	

33	Repeated Door-close	Should an obstacle prevent the doors from closing, the doors will repeatedly open and close until the obstacle is cleared from the doorway.	
34	Safety Door Edge	The sensitive door edge detects passengers or objects during door closing.	
35	Automatic Bypass	A fully-loaded car bypasses hall calls in order to maintain maximum operational efficiency.	
36	Car Fan Shut Off— Automatic	If there are no calls for a specified period, the car ventilation fan will automatically turn off to conserve energy.	
37	Car Light Shut Off— Automatic	If there are no calls for a specified period, the car lighting will automatically turn off to conserve energy.	
38	False Call Canceling— Automatic	If the number of registered car calls does not correspond to the car load, all calls are canceled to avoid unnecessary stops.	
39	False Call Canceling— Car Button Type Automatic	If a wrong car button is pressed, it can be canceled by quickly pressing the same button again twice.	
40	Overload Holding Stop	A buzzer sounds to alert the passengers that the car is overloaded. The doors remain open and the car will not leave that floor until enough passengers exit the car.	
41	Safe Landing	Service If a car has stopped between floors due to some equipment malfunction, the controller checks the cause, and if it is considered safe to move the car, the car will move to the nearest floor at a low speed and the doors will open.	
42	Basic Announcement Electronic	A synthetic voice (and/or buzzer) alerts passengers inside a car that elevator operation has been temporarily interrupted by overloading or a similar cause. (Should be in Hindi & English language.)	
43	LCD / LED Position Indicator	5-7-inch LCD / LED for car operating panels shows the date and time, car position, travel direction and elevator status messages.	
44	Hall LCD / LED Position Indicator	Display 5-7-inch LCD / LED for elevator halls shows the date and time, car position, travel direction and elevator status messages.	
45	Contactless Calling	Provision of contactless lift calling.	
46	Lift controller	The lift controller should be IOT based and capable to communicate the status of the lift such as floor number, upward / downward travel, alarm, entrapment etc. through wired/wirelessly.	
47	Guard skirting	Guard skirting inside the Car along the car walls to minimize the damage to the car body by goods.	
48	C-channel	C- channels below landing Sill, running through out length of landing sill.	
49	Rescue	There should be manual rescue (hand winding).	
50	Condition for lift OEM	The OEM should have an established service center operational since last 3 years within 75 Km road distance from IIT Roorkee (main campus) at the time of submission of bid.	
51	Condition for lift OEM	The OEM shall provide lift monitoring system which will enable the user to monitor the lifts from remote. This shall include door status (open/ close), floor number, real-time notifications, error history.	

Signature of Bidder

Signature of OEM

Goods cum passenger Lift:

The lift shall be made with the following cage dimensions of lift recommended for passenger lift by Bureau of Indian Standards.

Load (Kg)	Door	Car Inside (min.)		Lift Shaft		Entrance (min.)	Door Height (min.)	Pit Depth (min.)
		Width	Depth	Width	Depth	Width		
2000	COAD	1500	2700	2550(or as per existing structure and site condition)	3300(or as per existing structure and site condition)	1300	2000	1800(or as per existing structure and site condition)
	TLAD					1300		
1600	COAD	1400	2400	2550(or as per existing structure and site condition)	3000(or as per existing structure and site condition)	1300	2000	1800(or as per existing structure and site condition)
	TLAD					1300		
1000	COAD	1600	1550	2250(or as per existing structure and site condition)	2050(or as per existing structure and site condition)	1000	2000	1600(or as per existing structure and site condition)
	TLAD					1000		

Note: All dimensions are in mm.

*Normal range for Car Height is 2100 mm to 2400 mm.

TLAD: Telescopic Automatic Door.

COAD: Centre Opening Automatic Door.

Minimum rated load shall be not less than 3.45 kN/m² of the net inside car floor area.

1. **Pit:** Pit shall be soundly constructed and maintained in a dry (water proofed) and clean condition. The floor of the pit shall be able to support beneath the car buffer supports, force in Newton, equal to 4 times the static load being imposed by the mass of fully loaded car. The floor of the pit shall be able to support beneath the counterweight buffer support, force in Newton, equal to 4 times the static load being imposed by the mass of the counterweight. Pit ladder shall be provided in case pit depth is greater than 1300 mm below the lowest landing sill.
2. **Main Switches:** For each lift, a main switch capable of breaking the supply to the lift on all the live conductors shall be provided. This switch shall be capable of interrupting the highest current involved in normal conditions of use of the lift. This switch shall not cut the circuits feeding the following:
 - a) Car lighting and ventilation.
 - b) Socket outlet on the car roof.
 - c) Lighting of machinery spaces.
 - d) Socket outlet in the machinery and pulley spaces and in the pit.
 - e) Lighting of the lift well including pit.
 - f) Alarm device.
 - g) Automatic rescue device.
3. **Emergency signal and telephone:** The lift car shall be provided with an emergency signal that is operative from the lift car and audible outside the lift well and with a telephone.
4. The lift shall have VVVF motor drive. Under normal operation the levelling accuracy of the lift car shall be ± 12 mm.
5. The bottom run-by for car and counter weights shall not be less than 150mm.
6. **Landing Signals:** Where, prior to entering the car, the control system may establish the next direction of travel (collective control) the following shall be provided:
 - c) Two illuminated indicator arrows giving advance information on the next departure direction of the car (only one at the terminal landings) placed above or near the doors in a visible position, to indicate the direction in which the car will subsequently move. Landing indicator arrows shall be located between 1.80 m and 2.50 m above the floor. The height of arrows shall be 40 mm to 70 mm or as per OEM.
 - d) An audible signal shall accompany the lighting of the arrows. The audible signal in local language(s) shall have a sound level of between 35 d BA and 55 d BA adjustable to suit the site conditions or as per OEM.
7. A car position signal shall be located with or above the car operating panel. The centre line of the indicator shall be positioned between 1.60 m and 1.80 m from the car floor.

8. The height of the floor number shall be between 25 mm and 60 mm and have a contrasted colour to its surround or as per OEM.
9. Lift car doors and landing doors shall be of the horizontally sliding type, power operated and automatically controlled.
10. An audible signal shall be provided to signify the closing of the doors to alert persons.
11. When the car stops, a voice shall indicate, in the local language(s) the car position. The sound level of the information shall be adjustable between 35 dBA and 55 dBA adjusted to suit the site conditions.
12. Battery operated/ back up emergency light, alarm and intercom shall be provided.
13. **Overload Prevention Device:** The lift car shall not start when the car is overloaded. The lift operation shall resume only upon removal of the overload.
14. Braille and tactile markings shall be placed either on or to the left of the control buttons.
15. The emergency alarm push button shall be in a tactile bell shape.
16. An emergency alarm push button together with a buzzer, an indication light for acknowledgement and an intercom shall be provided in each lift car and be connected to the building management office or the caretaker's office.
17. Management office or the caretaker's office shall be equipped with a buzzer, indication light(s) (one for each lift) and an intercom connected to the lift car(s). The indication light for acknowledgement shall be in the form of a blinking light adjacent to the intercom speaker and a notice "When light blinks, it indicates your emergency call has already been received. Please be patient and wait for the rescue." In English and Hindi shall be provided next to the blinking light.
18. This system shall be powered by an emergency electricity supply system in the event of power failure.

Annexure-D

Basic Specification for Goods cum passenger Lift			
S. No.	Features	Technical Detail	Offered by the Bidder
1	Rated speed (m/sec)	Less than 1.0meter /sec.	
2	Rated capacity (kg)	1000/ 1600/ 2000	
3	Entrance width (mm)	As per above table	
4	Interior	Brush finish / Hairline finish Stainless Steel	
5	Flooring	Chequered Flooring	
6	Light & Fan	LED light/ 300mm with grill	
7	Hall position indicators and buttons	Segment LCD / LED Indicators, Tactile button along with additional brail inscriptions	
8	Floor	As per site.	
9	Handrail system	SS Hand railing.	
10	Travel	As per site.	
11	Stops & Opening	As per site.	
12	Ventilation	As per manufacturer	
13	Operation	Microprocessor based Simplex Collective Selective Control with/without Attendant.	
14	Power Supply	415 Volts ± 10%, 3 Phase, 50 Hz AC systems.	
15	Controller type	V3F (Variable Voltage Variable Frequency)	
16	Type of Machine	Gearless MRL	
17	Car Enclosure	Stainless steel scratches proof (Moon Rock / Honeycomb / Hairline Finish) on all sides.	
18	Car door enclosure	Glass doors SS frame & SS jamb	
19	Landing door enclosure	Glass doors SS frame & SS jamb	
20	Indicators (Car Landing)	Digital Direction & Position Indicator	
21	Type of Doors	Car: Auto Telescopic Opening	
		Landing doors: Auto Telescopic Opening	
22	Construction type	Machine Room Less	
23	Emergency Car Lighting	Car lighting which turns on immediately when power fails, providing a minimum level of lighting within the car.	
24	Fire Emergency Return	Upon activation of a key switch or a building's fire alarm, all calls are canceled, all cars immediately return to a specified evacuation floor and the doors open to facilitate the safe evacuation of passengers.	
25	Emergency Landing Device (Automatic rescue Device)	Upon power failure, a car equipped with this function automatically moves and stops at the nearest floor using a rechargeable battery, and the doors open to facilitate the safe evacuation of passengers. Dry type Battery (Maintenance Free) should be used for power backup.	
26	Automatic Door Speed Control	Door load on each floor, which can depend on the type of hall doors, is monitored to adjust the door speed, thereby making the door speed consistent throughout all floors.	
27	Door Load Detector	When excessive door load has been detected while opening or closing, the doors Door Load Detector immediately reverse.	
29	Door Nudging Feature — With Buzzer	A buzzer sounds and the doors slowly close when they have remained open for longer than the preset period.	
30	Multi-beam Door Sensor	Multiple infrared-light beams cover at least 2/3 of the door height of the doors to detect passengers or objects as the doors close.	
31	Reopen with Hall Button	Closing doors can be reopened by pressing the hall button corresponding to the traveling direction of the car.	
32	Repeated Door-close	Should an obstacle prevent the doors from closing, the doors will repeatedly open and close until the obstacle is cleared from the doorway.	

33	Safety Door Edge	The sensitive door edge detects passengers or objects during door closing.	
34	Automatic Bypass	A fully-loaded car bypasses hall calls in order to maintain maximum operational efficiency.	
35	Car Fan Shut Off — Automatic	If there are no calls for a specified period, the car ventilation fan will automatically turn off to conserve energy.	
36	Car Light Shut Off — Automatic	If there are no calls for a specified period, the car lighting will automatically turn off to conserve energy.	
37	False Call Canceling— Automatic	If the number of registered car calls does not correspond to the car load, all calls are canceled to avoid unnecessary stops.	
38	False Call Canceling— Car Button Type Automatic	If a wrong car button is pressed, it can be canceled by quickly pressing the same button again twice.	
39	Overload Holding Stop	A buzzer sounds to alert the passengers that the car is overloaded. The doors remain open and the car will not leave that floor until enough passengers exit the car.	
40	Safe Landing	Service If a car has stopped between floors due to some equipment malfunction, the controller checks the cause, and if it is considered safe to move the car, the car will move to the nearest floor at a low speed and the doors will open.	
41	Basic Announcement Electronic	A synthetic voice (and/or buzzer) alerts passengers inside a car that elevator operation has been temporarily interrupted by overloading or a similar cause. (Should be in Hindi & English language.)	
42	LCD / LED Position Indicator	5-7-inch LCD / LED for car operating panels shows the date and time, car position, travel direction and elevator status messages.	
43	Hall LCD / LED Position Indicator	Display 5-7-inch LCD / LED for elevator halls shows the date and time, car position, travel direction and elevator status messages.	
44	Contactless Calling	Provision of contactless lift calling calls.	
46	Lift controller	The lift controller should be IOT based and capable to communicate the status of the lift such as floor number, upward / downward travel, alarm, entrapment etc. through wired/wirelessly.	
47	Guard skirting	Guard skirting inside the Car along the car walls to minimize the damage to the car body by goods.	
48	C-channel	C- channels below landing Sill, running through out length of landing sill.	
49	Rescue	There should be manual rescue (hand winding).	
50	Condition for lift OEM	The OEM should have an established service center operational since last 3 years within 75 Km road distance from IIT Roorkee (main campus) at the time of submission of bid.	
51	Condition for lift OEM	The OEM shall provide lift monitoring system which will enable the user to monitor the lifts from remote. This shall include door status (open/ close), floor number, real-time notifications, error history.	

Signature of Bidder

Signature of OEM

Scope of Work:

For Part B: Comprehensive Annual Maintenance Contract:

1. CAMC will start after completion of the warranty period (i.e. 01 year from the date of handing over of the lift(s).
2. This contract covers attending any number of break down calls during normal working hours except for all National / Public holidays.
3. A monthly preventive maintenance service as per OEM norms must be carried out during the tenure of the contract. Also, major overhauling of the system shall be in the scope of bidder and shall be carried out as per OEM norms and EIC instructions as and when required.
4. All major and minor parts which requires repair / replacement due to normal wear and tear during the contract shall be replaced free of cost.
5. This contract does not cover shifting of units in part or as a whole.
6. The bidder shall depute only OEM/ OEM authorized service team for service/ maintenance work.
7. The bidder will be fully responsible for trouble-free and smooth operation of lifts during the period.
8. In case it is felt by the department that undue delay is being caused by the bidder in doing the rectification work, the same will be got done by the department at the risk and cost of the bidder. The decision of Dean Infrastructure in this regard shall be final.
9. In case of minor breakdown is not rectified within 02 days, a recovery shall be made @Rs. 1000/- per day from the time of reporting.
10. In case of major breakdown is not rectified within 07 days, a recovery shall be made @Rs. 1000/- per day from the time of reporting.
11. In case of continued non-performance and inability to meet service requirements, IIT Roorkee reserves the right to terminate the contract after giving 15 days' notice in writing. In addition, action may be taken for blacklisting / debarring of the bidder for future tenders/ works.
12. Bidder or their representative (with notarized power of attorney) is bound to attend the meeting (as and when called by EIC) for contract management (or any other issue related to contract) at IIT Roorkee. Penalty @ Rs. 5000/- per non-compliance shall be deducted from the bidder's bill or from the Performance Guarantee. In case the representative does not possess an adequate position or is unable to conclude meeting with logical end then the bidder is bound to attend such meetings.
13. EIC reserves the right to impose or wave off penalty fully or partially if justified on the request of the bidder and has the right to forfeit the Performance Guarantee / Bank Guarantee and / or blacklist the firm.
14. The bidder shall ensure compliance of all statutory and mandatory requirements, including all labour laws requirements. The bidder shall also keep IIT Roorkee indemnified against any liabilities that may arise on the account.
15. The bidder will be fully responsible for any accident or mishaps involving workers engaged by them and the bidder would pay claims made on this part. The Institute will not pay any compensation in this regard.

INSTITUTE WORK DEPARTMENT
INDIAN INSTITUTE OF TECHNOLOGY ROORKEE
Schedule of Quantities

NAME OF WORK: Supply, Installation, Testing and Commissioning of 13 Passenger and service (Goods cum Passenger) MRL Lifts with 8 stops for G+7 Building in the existing shaft including dismantling, removal and buyback of existing lift with accessories at Hill View Apartment & RK Bhawan at IIT Roorkee

BoQ

PRICE SCHEDULE							
(This BOQ template must not be modified/replaced by the bidder and the same should be updated after filling the relevant columns, else the bidder is liable to be rejected for this tender. Bidders are allowed to enter the Bidder Name and Values only)							
NUMBER #	TEXT #	NUMBER R #	TEXT #	NUMBER	TEXT #	NUMBER #	TEXT #
Sl. No.	Item Description	Quantity	Units	Estimated Rate with GST in Rs. P	Quoted Currency in INR / Other Currency	TOTAL AMOUNT With GST in Rs. P	TOTAL AMOUNT In Words
1	2	4	5	6	12	53	55
2	PART A: Supply, Installation Testing & Commissioning (SITC)						
2.1	Supply, Installation, Testing and Commissioning of a minimum 13 Passenger MRL Lift with 8 stops for the G+7 Building with granite floor finish in the existing shaft including dismantling, removal and buyback of existing lift with accessories. (For Hill View Apartment)	2	Each	3652766.000	INR	7305532.00	INR Seventy Three Lakh Five Thousand Five Hundred & Thirty Two Only
2.2	Supply, Installation, Testing and Commissioning of a minimum 13 Passenger Service MRL Lift (Goods cum Passenger) with 8 stops for the G+7 Building with granite floor finish in the existing shaft including dismantling, removal and buyback of existing lift with accessories (For Hill View Apartment).	2	Each	3652766.000	INR	7305532.00	INR Seventy Three Lakh Five Thousand Five Hundred & Thirty Two Only
2.3	Supply, Installation, Testing and Commissioning of a minimum 13 Passenger MRL Lift with 8 stops for the G+7 Building with granite floor finish in the existing shaft including dismantling, removal and buyback of existing lift with accessories. (For RK Bhawan)	3	Each	3652766.000	INR	10958298.00	INR One Crore Nine Lakh Fifty Eight Thousand Two Hundred & Ninety Eight Only
2.4	Supply, Installation, Testing and Commissioning of a minimum 13 Passenger Service MRL Lift (Goods cum Passenger) with 8 stops for the G+7 Building with granite floor finish in the existing shaft including dismantling, removal and buyback of existing lift with accessories (For RK Bhawan).	3	Each	3652766.000	INR	10958298.00	INR One Crore Nine Lakh Fifty Eight Thousand Two Hundred & Ninety Eight Only
2.5	Minor Civil work, minor architectural work (front wall stonework), complete water proofing of side wall and floor of lift pit etc.	10	Job	247450.000	INR	2474500.00	INR Twenty Four Lakh Seventy Four Thousand Five Hundred Only
3	PART B: Comprehensive Annual Maintenance Contract (CAMC) for 05 years (on year to year basis) after expiry of Guarantee /Warranty period.						

3.1	First Year Comprehensive CAMC	10	Job	95000.000	INR	950000.00	INR Nine Lakh Fifty Thousand Only
3.2	Second Year Comprehensive CAMC.	10	Job	99750.000	INR	997500.00	INR Nine Lakh Ninety Seven Thousand Five Hundred Only
3.3	Third Year Comprehensive CAMC.	10	Job	104738.000	INR	1047380.00	INR Ten Lakh Forty Seven Thousand Three Hundred & Eighty Only
3.4	Fourth Year Comprehensive CAMC.	10	Job	109974.000	INR	1099740.00	INR Ten Lakh Ninety Nine Thousand Seven Hundred & Forty Only
3.5	Fifth Year Comprehensive CAMC.	10	Job	115473.000	INR	1154730.00	INR Eleven Lakh Fifty Four Thousand Seven Hundred & Thirty Only
Total in Figures (For Part A & Part B)						44251510.00	INR Four Crore Forty Two Lakh Fifty One Thousand Five Hundred & Ten Only
Quoted Rate in Figures (For Part A & Part B)			Select			0.00	INR Zero Only
Quoted Rate in Words (For Part A & Part B)		INR Zero Only					

Note:

1. In case the actual applicable GST rate in the BoQ is different from 18% then payment shall be made on the actual applicable GST rate while keeping the basic rate same.
2. Vendor will arrange safety gears such as safety shoes, safety helmets, gloves etc for the manpower deployed at his own cost. If the manpower is found not wearing safety gears, a penalty of Rs. 200 per violation will be imposed by the EIC.
3. The lowest bid shall be evaluated on the basis of total cost of Part-A & Part-B.
4. Tender will first be allotted for Part-A & then for Part-B (after completion of guarantee /warranty period) on yearly basis (depending on the performance of the bidder).
5. Bidder or their representative (with notarized power of attorney) is bound to attend the meeting (as and when called by EIC) for contract management (or any other issue related to contract) at IIT Roorkee. Penalty @ Rs. 5000/- per non-compliance shall be deducted from the bidder's bill or from the Performance Guarantee. In case the representative does not possess an adequate position or is unable to conclude meeting with logical end then the bidder is bound to attend such meetings.

Signature and stamp of the bidder

**Sd-
Institute Engineer,
IWD, IIT Roorkee**