	सामग्री प्रबंधन अनुभाग भारतीय प्रौद्योगिकी संस्थान, रुड़की रुड़की-247667, हरिद्वार, उत्तराखण्ड, भारत Phone-(O) 01332-28-4293, 4693 E-mail: mmiitr@iitr.ac.in	Material Management Section Indian Institute of Technology Roorkee-247667(Haridwar) (Uttarakhand) (India) Phone-(O) 01332-28-4293, 4693 E-mail: mmiitr@iitr.ac.in	
	GSTIN-05AAALI0033R1Z5	E-mail: mmiitr@iitr.ac.in	
	PAN-AAALI0033R		

निविदा प्रलेख / Tender Document

No. 2026270102/MM-6/IITR/2026-27/Semi Tooled up EV Chassis/MIED/104

Date of Uploading of Tender -<https://eprocure.gov.in/eprocure/app>

24-Jun-2026

Bids under two bid systems (Technical and Commercial) are invited Online at CPP Portal (<https://eprocure.gov.in/eprocure/app>) from the reputed manufacturer/authorized supplier/dealer for the following items. **Manual bids will not be accepted.**

वस्तु की तकनीकी विशिष्टताएँ / Technical Specifications of item:

Sr. No	Name of item / Specifications	QTY	UOM
1	Semi Tooled up EV Chassis & Subassemblies	100	Nos.
(For Detailed Technical Specification Plz refer Annexure-V)			
नोट-1: कृपया वस्तु का मूल्य एवं कर अलग-अलग दर्शाए।			
Note-1: Please quote the Rate & Taxes of the item separately.			
Note-2: E-way bill is to be issued by the Venders/Transporter			
Note-3: The HSN / SAC Code of the item must be mentioned.			
For Reasonability of Rates, The firm must enclose the last two supply orders for the same item with Financial Bid (Annexure-III) only.			
Critical Date Sheet			
1	Published Date	24-Jun-2026	(17:00)
2	Bid Document Download / Sale Start Date	24-Jun-2026	(17:30)
3	Seek Clarification Start Date	24-Jun-2026	(18:00)
4	Seek Clarification End Date	29-Jun-2026	(16:00)
5	Pre Bid Meeting Date	Not Required	Not Required
6	Bid Submission Start Date	30-Jun-2026	(15:00)
7	Bid Submission End Date	15-Jul-2026	(15:00)
8	Bid Opening Date	15-Jul-2026	(15:30)

Chapter-1 : Instruction to bidders

- A. The Tender should be enclosed with proper certifications like Agency Certification, Authorization certificate and/or Proprietary Certificate, as the case may be, in support of your offer.
- B. बोली का जमा किया जाना / **Submission of Bids:**
The bids should be submitted online in two parts –
 - 1 (i) **The Technical Bid (Annexure-I, II, IV & V) and Tender Acceptance Letter**
 (ii) **The Financial Bid (Annexure-III) & Price Bid in .XLS Format**
Rates in .xls format will only be considered for Financial evaluation & further processing.
 - 2 The bids should be on official pad preferably with GST Number of the firm

- 3 The quotations should bear full details and where possible may be duly supported with catalogues, pamphlets, literature, samples of the item/items as the case may be for comparing the quality and rates of the item(s).
- 4 The transportation cost, insurance charge etc., if any, percentage/ rate of GST or all other taxes and duties should be clearly mentioned.
- 5 The bids / rates / tenders should remain valid for a minimum period of 90 days from the date of financial opening.
- 6 The rates shall not be subject to escalation of any nature.
- 7 The rates quoted should be applicable to educational institutions and any cost advantage received in lieu thereof should be passed on the Institution.
- 8 While quoting / sending rates, the firm shall give an undertaking as per Annexure-II.

C. विधि निक्षेप/ Earnest Money Deposit (EMD):

In lieu of Bid Security/Earnest Money Deposit (EMD), declaration as per Appendix-A should be provided.

D. निष्पादन बैंक प्रत्याभूति/ Performance Bank Guarantee (PBG):

In case the total order value of items becomes Rs.25.00 Lakhs or above, 3% of the total order value in the form of Bank Guarantee or FDR pledged in favor of "The Registrar, IIT Roorkee" is required at the time of installation of the equipment which should remain valid at least during the warranty period plus sixty days. No interest shall be claimed by the bidder on the PBG submitted.

E. बोलियों का खोला जाना/ Opening of Bids:

- 1 The Technical Bids will be opened online at CPPP Portal (<https://eprocure.gov.in/eprocure/app>)-Plz refer Critical Date Sheet
- 2 The Financial bids of only the Technically Qualified bidders will be opened. The date and time for opening the Financial Bid will be communicated to the respective firm later by the system (CPP Portal (<https://eprocure.gov.in/eprocure/app>))
- 3 Representatives of the firms(s) may be present at the time of openings, if they so desire.

Chapter-2 : Conditions of Contract

F. ठेका देना/ Award of Contract:

The final selection of the bidder for the award of the contract will be made on the basis of the lowest commercial bid amongst the Technically Qualified Bidders.

Prices of optional item will not be considered to identify lowest price bid.

G. पूर्व-आपूर्ति निरीक्षण/ Pre-supply Inspection:

Authorized representative of the Institute shall make the final inspection before supply of the item at site of the firm, if required.

H. वस्तु की आपूर्ति/ Supply of Item:

The whole supply as per order shall have to be completed within the time mentioned in the order failing which the I.I.T. Roorkee shall have the right to accept or reject any quantity of items ordered. The firm will have to arrange for supply of the material in good condition.

I. भुगतान की शर्तें/ Payment Terms:

A. Payment in INR for supply of goods:

Where installation is not required: 100% payment will be made after satisfactory delivery of material duly certified by the HOD/P.I.

OR

Where Installation is required :100% payment will be made after satisfactory delivery and installation of the material duly certified by the HOD/P.I.

OR

Upto 80% payment on receipt and acceptance of goods/service by the indenter and the balance on successful installation and commissioning by the supplier and acceptance by the indenter.

B. Payment in INR for AMC/Service:

Quarterly/Halfyearly after satisfactory completion of work/service duly certified by the H.O.D./P.I.

J. दंड/Penalty:

A penalty of 0.5% of the total order value per week shall be levied for the delay subject to a maximum of 5% of the total order value.

In case of the non-supply of the item/service after the acceptance of the work/supply order, EMD & PBG (if submitted) will be forfeited by the Institute. Also, the firm will be debarred from any future bidding process of IIT Roorkee for a period of a minimum two year.

K. अप्रत्याशित घटना/Force Majeure:

For the purpose of and within the scope of contract by way of indication and not of limitation, the term “Force Majeure” shall mean acts of nature, strikes, Lockouts, or other industrial disturbances, act of public/enemy, wars, blockades, insurrection, riots, epidemics, landslides, earthquakes, storms lightening, flood, washouts, civil disturbances, explosion and any other similar even not within the control of either party on which by exercise of due care and diligence neither party is able to prevent or overcome.

L. मध्यस्थता / Arbitration:

If any dispute which may arise with respect to any term and condition or with respect to the interpretation of any term and condition of the Purchase Order/Work Order, which may be issued to the qualified and successful tenderer subsequently, the same shall be settled strictly in accordance with and in compliance of the Arbitration procedure which is mentioned descriptively in the Purchase Order/ Work Order.

M. बोली अस्वीकृती के लिए मानदंड / Criteria for bid rejection:

1 If technical bid found without the required undertaking (Annexure-II), EMD & Self Certificate (Annexure-IV)

2 If it found at a later date that any information given in the bids is Incorrect/false then the bid is liable to be disqualified/rejected.

3 Canvassing in any form will result to disqualification.

4 If “extra, as actual” etc. are mentioned against any of the price components in the bid the bid will be rejected.

5 If the firm quotes 'NIL' charges / consideration, the bid shall be treated as unresponsive and will not be considered.

6 If financial bid is found along with technical bid in pdf on CPP Portal, then the bid shall be rejected outrightly.

7 If any bidder submitting two/multiple bids for the same item of a tender, both/all the bids of that bidder will be outrightly rejected.

Chapter-3 : Schedules of requirements

N. टिप्पणी / Note:

1 If the supplier/firm is manufacturer/authorized dealer/sole distributor/of the item, the certificate to this effect should be attached.

2 Please note that the firms must submit the compliance Statement in an organized and structured manner in respect of all the specifications as per Annexure-V with the supporting catalogue/leaflet of the firm. Annexure-I, II, & IV have to be submitted with Technical Bid and Annexure-III with financial bid.

3 It may also be noted that the tender bids received after the stipulated date & time or found incomplete and the tender bids containing false/incorrect information shall be summarily rejected. The Institute shall not entertain any communication in this regard, whatsoever.

4 The firm is required to give its Bank Account details with IFSC for the purpose of making e-payment.

5 The Indian Institute of Technology (IIT) Roorkee reserves the right to reject any quotation wholly or partly without assigning any reason.

6 The quantity shown in the tender can be increased or decreased to any extent depending upon the actual requirement.

7 The decision of the institute in all matters relating to eligibility, acceptance, rejection of the bid will be final and binding on the applicants.

8 IIT Roorkee discourages High Sea Sale purchase. All tenders with High Sea Sale will be rejected.

9 The firms should clearly mention (in the financial bid) the Harmonized System of Classification (HS code) defined by the Central Custom and Excise Board (Govt. of India)- for the item(s) involving import.

10 **If the bid opening date happens to be a holiday, then the bid will be opened at 3.30PM of the next working day followed by the holiday.**

11 If an agent submits bid on behalf of the Principal/OEM, the same agent can not submit a bid on behalf of another Principal/OEM in the same tender for the same item/product.

12 Indian Agent should submit the certificate from the Foreign Principal that they are the Authorized & Registered Indian Agent.

13 The quantity shown against the item is approximate and may vary as per demand of the Institute at the time of placing order. Also, the final requirement of each line item will be decided by the Institute at the time of placing the PO.

14 **Any corrigendum/addendum/errata in respect of the Tender Notice/ Enquiry letter shall be made available CPP Portal (<https://eprocure.gov.in/eprocure/app>). Hence prospective bidders are advised to visit the CPP Portal (<https://eprocure.gov.in/eprocure/app>) regularly.**

15 Bidders shall be responsible for the correctness of the information provided in the enquiry letter/tender document. If it is found at a later date that any information given in the bid is Incorrect/false then the bid is liable to be disqualified/rejected.

16 Before submission of bids, bidders should read the complete enquiry letter/tender document carefully and ensure that the bidders fulfill the eligibility criteria.

- 17 In case the item/product is under rate contract with DGS&D or GeM, then Bidder should certify that the rate quoted is not over and above (higher side) the rates under RC with the DGS&D or GeM.
- 18 **In Item Wise BoQ .xls sheet, In column M, leave blank for the item/service not provided/quoted by you. If quoted 0 then it will be considered that the item/service will be provided free of cost.**
Or
In Item Rate BoQ .xls sheet, If quoted 0 for the items/services in column M then it will be considered that the items/services will be provided free of cost.
- 19 **The bidder must quote the applicable GST appropriately in the price bid format provided i.e BoQ in .xls format. In case column of GST left blank, quoted 0, or inappropriate, then total quoted amount shows in column BB would be final inclusive of GST & other charges. The difference in GST amount payable – if any will be borne by the bidder. In this case, the basic unit prices will be suitably adjusted by the bidder – if required.**
- 20 **Only 'Class-I local supplier' and 'Class-II local supplier', as defined in the Public Procurement (Preference to Make in India), Order 2017 shall be eligible to bid in tender. For more details please refer: Order No.: P-45021/2/2017-PP (BE-II), DPIIT, Ministry of Commerce and Industry issued Dated: 16th Sept. 2020.**
Self-certificate has to be provided in this regard that the item offered meets the local content requirement for 'Class-I local supplier' & 'Class-II local supplier'. (As per annexure-IV)
- 21 **The Institute reserves the right to rectify any discrepancy of this advertisement, if found later on. In case of any inadvertent mistake in the process which may be detected at any stage even after the issue of purchase order, the Institute reserves the right to modify/withdraw/cancel any communication made to the bidder.**

Chapter-4 : Specifications and allied Technical details

Plz. See Annexure- I, II, IV, V

Chapter-5 : Price Schedule (to be utilized by the bidders for quoting their prices online in .XLS format at CPPP Portal (<https://eprocure.gov.in/eprocure/app>))

Plz. See Annexure- III & Price Bid in .XLS Format

Chapter-6 : Contract Form

Purchase Order is used as Contract Form

Chapter-7 : Other Standard Forms, if any to be utilized by the purchaser and bidders

Tender Acceptance Letter

***उप कुलसचिव (सामग्री प्रबंधन)
Deputy Registrar (MM)**

***Document Digitally Signed on <https://eprocure.gov.in/eprocure/app>**

For any Clarification regarding technical specifications of item Please Contact:

**Prof. Akshay Dvivedi
MIED
IIT Roorkee**

**MIED
IIT Roorkee**

**Ph.- 01332-28-5428
Email: akshaydvivedi@me.iitr.ac.in**

तकनीकी बोली

विस्तृत विवरण अनुपालन रिपोर्ट के साथ प्रस्तुत किया जाना है (अपने आधिकारिक लेटर हेड पर विक्रेता/फर्म द्वारा प्रस्तुत करने के लिए)

Detailed specification cum compliance report to be submitted with the Technical Bid
(to be submitted by the vendor/firm on its official letter head)

(For Detailed Technical Specification Plz refer Annexure-V)

Sr.No	Name & Required Specifications of Item(s)	Qty	UOM	Offered specifications of item(s) by the firm
1	Semi Tooled up EV Chassis & Subassemblies	100	Nos.	
	Firm's Profile :			
1	Manufacturer/Authorized Agent/Distributor/Dealer/Supplier(valid certificate must be attached)			
2	E-mail I.D. & Telephone/Mobile No. Detail of Bank A/C			
Note:	1. "offered specifications", should be filled up properly in the format provided as per Annexure-I.			
	2. Volume & Weight of the item should also be mentioned.			
	3. The HSN / SAC Code of the item must be mentioned.			

Signature: _____

Name : _____

Designation : _____

Seal of the Organisation

उपबंध / UNDERTAKING

Ref. No. No. 2026270102/MM-6/IITR/2026-27/Semi Tooled up EV Chassis/MIED/104
Dated:- 24-Jun-26

I/We hereby certify that we or Our OEM are not from such a country which shares a land border with India or, if from such a country, We are registered with the Competent Authority. [Where applicable, evidence of valid registration by the Competent Authority is attached.]" (For details Please refer Order No.: F.No. 6/18/2019-PPD Dt.: 23rd July 2020)

Link of Order: [http://mm.iitr.ac.in/mmweb/public/forms/63374_GFR%20Rule%20144%20\(xi\).pdf](http://mm.iitr.ac.in/mmweb/public/forms/63374_GFR%20Rule%20144%20(xi).pdf)

That all the terms/conditions mentioned in the enquiry letter/tender against which the rates are being given are acceptable to the firm.

It is certified that the rate quoted is not over and above (higher side) the rates under RC with the DGS&D or GeM.

It is certified that the firm has never been black-listed from any Government Department. (State/Central Govt./ Autonomous/ PSU) in the last three years.

Signature _____

Name _____

Designation _____

Seal of the Firm/Agency

Financial Bid

(to be submitted by the vendor/firm on its official letter head)

Ref. No. No. 2026270102/MM-6/IITR/2026-27/Semi Tooled up EV Chassis/MIED/104
Date: 24-Jun-26

Rates :

Sr. No	Name of item / Specifications	Qty	UOM	Rate	Amount (INR Only)
1	Semi Tooled up EV Chassis & Subassemblies	100	Nos.	To be filled in .XLS sheet (attached)	
Total					
Grand Total Rs.					

1) Price of the items should be clearly mentioned if supplied Free of Cost.

Terms & Conditions:

- 1 Prices (quoted in Rs.): FOR MIED
IIT Roorkee
- 2 **Payment:** **Should be clearly mentioned, As per clause-I of tender document.**
- 3 Validity:
- 4 Delivery period:
- 5 Other charges:
- 6 **Warranty:**
- 7 Rejection: Equipment if found not as per the required specification would be rejected.
- 8 Penalty Clause: As per clause-J of tender document.
In case of the non-supply of the item/service after the acceptance of the work/supply order, EMD & PBG (if submitted) will be forfeited by the Institute. Also, the firm will be debarred from any future bidding process of IIT Roorkee for a period of a minimum two year.
- 9 PBG: In case the total order value of items becomes Rs.25.00 Lakhs or above, 3% of the total order value in the form of Bank Guarantee or FDR pledged in favor of "The Registrar, IIT Roorkee" is required at the time of installation of the equipment which should remain valid at least during the warranty period plus sixty days. No interest shall be claimed by the bidder on the PBG submitted.

It is certified that the rate quoted is not over and above (higher side) the rates under RC with the DGS&D or GeM.

Signature_____

Name_____

Designation_____

Seal Of the Firm/Organization_____

Details of Institute :

IEC CODE	0100000011	
AD CODE	0001069-2770325	S.B.I., IIT ROORKEE
	0303974-2770324	P.N.B. IIT ROORKEE

(to be submitted by the vendor/firm on its official letter head)

Self-Certificate for Local Content

Tender No.: No. 2026270102/MM-6/IITR/2026-27/Semi Tooled up EV
Chassis/MIED/104

24-Jun-26

We hereby certify that the items quoted by us against above mentioned tender no. has the local content as per below:

Local Content (in %):.....

Local Supplier Class:.....

The details of the Make in India items/parts used in the quoted products is/are as under:

- 1
- 2
- 3

The details of the location(s) at which the local value addition made/manufactured is/are as under:

- 1
- 2
- 3

We also understand, false declarations will be in breach of the code of integrity under rule 175(1)(i)(h) of the General Financial Rules for which a bidder or its successors can be debarred for up to two years as per Rule 151(iii) of the General Financial Rules along with such other actions as may be permissible under law.

Signature:

Name:

Designation:

Seal Of the Firm/Organization:

Instructions for Online Bid Submission

Instructions to the Bidders to submit the bids online through the Central Public Procurement Portal for e-Procurement at <https://eprocure.gov.in/eprocure/app>. Also, any modification on CPP portal in reference to below will be applicable. Therefore, for more details and update please refer CPP Portal (<https://eprocure.gov.in/eprocure/app>).

- 1 Possession of valid Digital Signature Certificate (DSC) and enrollment/registration of the contractors/bidders on the e-Procurement/e-tender portal are prerequisite for etendering.
- 2 Bidder should register for the enrollment in the e-Procurement site using the "Online Bidder Enrollment" option available on the home page. Portal enrollment is generally free of charge. During enrollment/registration, the bidders should provide only valid and true information including valid email id. All the correspondence shall be made directly with the contractors/bidders through email id as registered.
- 3 Bidder need to login to the site through their user ID/ password chosen during enrollment/registration.
- 4 Then the Digital Signature Certificate (Class III Certificates with signing key usage) issued by SIFY/nCode/eMudra etc. recognized by Controller of Certifying Authorities (CCA) India on eToken/SmartCard, should be registered.
- 5 The registered DSC only should be used by the bidder in the transactions and should ensure safety of the same.
- 6 Contractor/Bidder may go through the tenders published on the site and download the tender documents/ schedules for the tenders.
- 7 After downloading/getting the tender document/schedules, the Bidder should go through them carefully and then submit the documents as required, otherwise bid will be rejected.
- 8 Any clarifications may be sought online through the tender site, through the contact details or during pre-bid meeting if any. Bidder should take into account the corrigendum if any published before submitting the bids online.
- 9 Bidder may log in to the site through the secured login by the user id/ password chosen during enrolment/registration and then by submitting the password of the e-Token/Smartcard to access DSC.
- 10 Bidder may select the tender in which he/she is interested in by using the search option and then move it to the 'my tenders' folder.
- 11 From my tender folder, he may select the tender to view all the details uploaded there.
- 12 It shall be deemed that the bidder has read and understood all the terms and conditions before submitting the offer. Bidder should go through the tender schedules carefully and upload the documents as asked; otherwise, the incomplete bid shall stand rejected.
- 13 Bidder, in advance, should get ready the bid documents to be submitted as indicated in the tender document/ schedule and ordinarily it shall be in PDF/xls/rar/jpg/dwf formats. If there is more than one document, all may be clubbed together and provided in the requested format. Bidders Bid documents may be scanned with 100 dpi with black and white option. It is advisable that each document to be uploaded through online for the tenders should be less than 2 MB. If any document is more than 2MB, it can be reduced through zip/rar and the same if permitted may be uploaded. The file size being less than 1 MB the transaction uploading time will be very fast.
- 14 The Bidders can update well in advance, the documents such as certificates, annual report details etc., under "My Space option" and these can be selected as per tender requirements and then send along with bid documents during bid submission. This will facilitate the bid submission process faster by reducing upload time of bids.
- 15 Bidder should submit the Tender Fee/ EMD as specified in the tender. Scanned copy of the same should be uploaded as part of the offer. (if applicable)
- 16 While submitting the bids online, the bidder shall read the terms and conditions and may accept the same to proceed further to submit the bid packets.
- 17 The bidder has to select the payment option as offline to pay the Tender FEE/ EMD as applicable and enter details of the same. (if applicable)
- 18 The details of the DD/any other accepted instrument, physically delivered, should tally with the details available in the scanned copy and the data entered during bid submission time, otherwise submitted bid shall not be acceptable or liable for rejection. (If applicable)
- 19 The bidder has to digitally sign and upload the required bid documents one by one as indicated. Every act of using DSC for downloading the bids and uploading their offers shall be deemed to be a confirmation that they have read, understood and agreed with all clauses of the bid document including General conditions of contract without any exception.

- 20 The bidder has to upload the relevant files required as indicated in the cover content. In case of any irrelevant files, the bid may be rejected.
- 21 If the price bid format is provided in a spread sheet file like BoQ_XXXX.xls, the rates offered should be entered in the allotted space only and uploaded after filling the relevant columns. The Priced-bid/BOQ template shall not be modified / replaced by the bidder; else the bid submitted is liable to be rejected for the tender.
- 22 The bidders are advised to submit the bids through online e-tendering system to the Tender Inviting Authority (TIA) well before the bid submission due date and time (as per Server System Clock). The TIA shall not be held responsible for any delay or the difficulties faced during the submission of bids online by the bidders.
- 23 After the bid submission (i.e. after Clicking "Freeze Bid Submission" in the portal), the acknowledgement number indicated by the system should be printed by the bidder and kept as a record of evidence for online submission of bid for the particular tender and also be used as entry pass to participate in the bid opening.
- 24 The time settings fixed in the server side and displayed at the top of the tender site, shall remain valid for all actions of requesting, bid submission, bid opening etc., in the e- Tender system. The bidders should follow such time during bid submission.
- 25 All the data being entered by the bidders would be encrypted using Public Key Infrastructure (PKI) encryption techniques to ensure the secrecy of the data. The data entered is not retrievable by unauthorized persons during the bid submission and until the time of bid opening by any person.
- 26 Any bid document that is uploaded to the server is subjected to symmetric encryption using a system generated symmetric key. Further this key is subjected to asymmetric encryption using buyers/bid openers' public keys. Overall, the uploaded tender documents become readable only after the tender opening by the authorized bid openers.
- 27 The confidentiality of the bids is maintained with the use of Secured Socket Layer (SSL) 128 bit encryption technology. Data storage encryption of sensitive fields is done.
- 28 The bidder should logout of the tendering system using the normal logout option available at the top right hand corner and not by selecting the (X) exit option in the browser.
- 29 For any queries regarding e-Tendering process, the bidders may contact at address as provided in the tender document. Parallely for any further queries, the bidders are advised to contact over phone: **0120-4001005** or send an e-mail to – cppp-nic@nic.in.

Prequalification

- 1 An undertaking by the firm that it has never been black-listed in the last three years must be attached along with the Bid, failing which the Bid shall be rejected. (As per Annexure-II)
- 2 True copy of Permanent Account Number.
- 3 Details of GST along with a copy of certificate to be attached.
- 4 Submission of samples if required, for all items indicated in the NIT. The make of items proposed to be supplied should be indicated and submitted along with the techno commercial unpriced bid without indicating the pricing components.
- 5 Willingness to execute all orders which are placed to meet emergency requirement on priority basis. The Bidder shall note that standards for workmanship, material and equipment, and references to brand names designated by the Purchaser in the tender document are intended to be descriptive only and not restrictive. The Bidder may substitute alternative standards, brand names and/or catalogue numbers in his bid, provided that it demonstrates to the Purchaser's satisfaction that the substitutions ensure substantial equivalence to those designated in the Technical Specifications.

Tender Acceptance Letter
(To be given on Company Letter Head)

Date:

Sub: Acceptance of Terms & Conditions of Tender.

Tender No. 2026270102/MM-6/IITR/2026-27/Semi Tooled up EV Chassis/MIED/104

Tender description:

Dear Sir,

- 1 I/We have downloaded/ obtained the tender document(s) for the above mentioned 'Tender No.' from the web site(s) namely:

as per your advertisement, given in the above mentioned website(s).
- 2 I/We hereby certify that I/We have read the entire terms and conditions of the tender documents from Page No. _____ to _____ (including all documents like section(s), schedules(s) etc.), which form part of the contract agreement and I/we shall abide hereby by the terms/conditions/ clauses contained therein.
- 3 The corrigendum(s) issued from time to time by your department/ organisation too have also been taken into consideration, while submitting this acceptance letter.
- 4 I/We hereby unconditionally accept the tender conditions of above mentioned tender document(s)/ corrigendum(s) in its totality/entirety.
- 5 In case any provisions of this tender are found violated, then your department/organisation shall without prejudice to any other right or remedy be at liberty to reject this tender/bid including the forfeiture of the full said earnest money deposit absolutely.

Yours Faithfully,

(Signature of the Bidder, with Official Seal)

DECLARATION
(to be submitted by the vendor/firm on its official letter head)

**To,
Registrar,
IIT Roorkee,
Roorkee,**

Subject: Undertaking in lieu of Bid Security/Earnest Money Deposit (EMD)

Tender Ref no: No. 2026270102/MM-6/IITR/2026-27/Semi Tooled up EV Chassis/MIED/104

24-Jun-26

Dear Sir,

We, the undersigned, offer to Supply the
..... as per tender at IIT Roorkee, in response to your above refered tender no.

We are hereby submitting our proposal/Bid/Quote for the same, which includes Technical bid and the Financial Bid. As a part of eligibility requirement stipulated in above refered tender document, we hereby submit a declaration in lieu of Earnest Money Deposit (EMD) as given below:

1. Our bid shall remain valid for 90-days from the date of financial opening and that we will not withdraw or modify our bid during the validity period,
2. In case, we are declared as successful bidder and an order is placed on us, we will submit the acceptance in writing within 7 days of placement of order on us.
3. In case, we are declared as successful bidder and an order is placed on us, we undertake, to submit a Performance Bank Guarrantee(PBG) as mentioned in above refered tender document or as per terms stipulated in the Purchase Order.
4. In case of failure on our part to comply with any of the above said requirements, we are aware that we shall be declared as un-eligible for said tender and /or debarred from any future bidding process of IIT Roorkee for a period of minimum one year.
5. The undersigned is authorized to sign this undertaking.

Signature:

Name:

Designation:

Seal of the Firm/Organization:

Technical Specification

Semi tooled up EV Chassis & Subassemblies

1. **Scope & Purpose:** This document provides a technical overview of the Semi tooled up electric vehicle (EV) chassis and subassemblies to be developed for the Modular Electric 2-Wheeler Platform, a project supported by the Ministry of Heavy Industries (MHI). It covers the chassis and Subassemblies design philosophy, materials to be used, fabrication processes, fixture strategy, dimensional requirements, and quality control methods to be followed during manufacturing.
2. **Chassis and Subassemblies Overview:** The semi tooled up chassis & Subassemblies needs to be a hybrid structure combining fabricated sheet metal panels with a tubular space-frame sub-structure. This approach needs to be adopted in these builds to enable rapid manufacturing and reducing heavy tooling investment. The assembly should be designed to include the all the EV components battery pack, motor mounts, suspension System, body mounting provisions and electrical hardwares in the most efficient as specified.
3. **Semi Proto Tooling Methodology needs to be :**
 - High dimensional repeatability
 - Structural consistency
 - Controlled welding distortion
 - Accurate mounting interface
 - Production-level tolerance
 - Consistent assembly quality across batches

Under this methodology, it is needed to develop and utilize manufacturing aids and process-control tools similar to those used in mass-production environments, including:

- Child-part fabrication fixtures
- Sub-assembly welding fixtures
- Main chassis welding fixtures
- Truing fixtures for dimensional correction and alignment
- Checking gauges for critical dimensions and mounting interfaces
- Inspection gauges for quality verification
- Assembly fixtures for subsystem integration
- Locating and clamping fixtures for repeatable manufacturing
- Weld positioning fixtures and jigs
- Dimensional inspection setups and master references

The semi-proto should have the following:

- Development of controlled fabrication and welding fixtures
- Better dimensional stability compared to manual prototype fabrication



- Improved alignment and repeatability of critical mounting points
- Structured quality inspection during fabrication
- Production-oriented manufacturing controls
- Reduced tooling investment while maintaining high manufacturing quality
- Production-representative components suitable for validation and testing

4. General Specifications

- **Vehicle Type:** Semi tooled up Two-Wheeler Chassis and Subassemblies
- **Construction Type:** Hybrid Sheet Metal + Tubular Frame
- **Intended Phase:** Pre-Production Validation
- **Assembly Type:** Welded Structural Assembly using welding fixtures

5. Material Specifications

5.1 Structural Tubular Members

Parameter	Specification
Tube Material	ERW Mild Steel (IS standard)
Tube Sections	40×40×2.5 mm, 40×20×2.0 mm
Tube Shape	Square / Rectangular
Sub-Frame Tubes	ERW Round Tubes
OD Range	25–38 mm
Thickness	2.0–3.0 mm

5.2 Sheet-Metal Components

Component	Material	Thickness
Floor Panel	IS 2062 Grade A MS	2.0–3.0 mm
Side Panels	IS 2062 Grade A MS	2.0–3.0 mm
Battery Tray	IS 2062 Grade A MS	2.5 mm

5.3 Mounting & Reinforcement Components

- **Gussets:** 4.0–6.0 mm MS plate
- **Brackets:** Mild steel plate
- **Cutting Requirement:** Profiles to conform to laser/plasma-cut geometries

6. Technical Requirements for Fabricated Components

6.1 Sheet-Metal Component Requirements

- Cut profiles shall maintain a dimensional accuracy of ± 1.5 mm.
- Bent sections must conform to designed bend angles without surface cracking.
- All edges must be free of burrs and sharp projections.
- Sheet components must maintain acceptable flatness before weld assembly.

6.2 Tube Component Requirements

- Linear and angular cuts shall meet $\pm 1^\circ$ angular tolerance.
- Tube ends shall maintain a joint clearance of **0.5–1.5 mm** when fitted.
- Tube bends must exhibit uniform wall distribution and minimal ovality.

7. Welding Requirements (Process-Neutral)

- Applicable welding category: **Structural MIG/GMAW**, with **TIG/GTAW** specified for high-stress or precision-critical joints.
- Weld consumable: **ER70S-6**, conforming to **AWS A5.18**.
- Welds must meet defined visual standards including:
 - No porosity clusters
 - Controlled undercut
 - Full fusion at load-bearing joints
- A symmetrical welding distribution strategy must be used to limit distortion.

8. Fixture & Assembly Requirements

- Fixture base shall be a levelled fabrication table or surface plate.
- The fixture must enable:
 - Establishing X-Y-Z datums
 - Ensuring tube and panel positioning repeatability
 - Maintaining squareness and alignment under clamping loads
- The fixture may be modular/reconfigurable to support iterative prototype builds.

9. Dimensional Tolerances

Parameter	Tolerance
Overall Length / Width / Height	$\pm 3-4$ mm
Suspension Pickup Centres	$\pm 2-3$ mm
Motor Mount Bolt Pattern	± 2 mm
Frame Squareness	± 4 mm
Base Rail Flatness	± 3 mm
Tube Joint Gap	0.5–1.5 mm
Fillet Weld Size	Design ± 1 mm
Angular Alignment	$\pm 1^\circ$

10. Quality Control Requirements

10.1 Instruments to be Used

- Steel tape
- Digital vernier caliper
- Feeler gauge
- Weld gauge



- Pin gauge
- Surface plate

10.2 Mandatory Inspection Points

- Datum referencing validation
- Diagonal squareness verification
- Suspension pickup point location check
- Motor mount alignment check
- Weld visual inspection
- Flatness measurement

10.3 Inspection Frequency

- Pre-fit (pre-tack): **100%**
- Intermediate: **100%**
- Final dimensional inspection: **100%**

11. Surface Finish Requirements

- Surface condition: Mill finish with weld dressing where necessary
- Burrs must be removed from all edges
- Local weld grinding permitted for fitment and clearance
- Recommended protective layers:
 - Epoxy primer
 - Anti-corrosion base coat

12. Semi tooled up builds Limitations

- Tolerances are acceptable for Semi tooled up builds only; not intended for mass production.
- Manual fixture variability of **1–2 mm** may occur.
- Additional structural validation required before production release.

13. Deliverables

- Completed Frame assembly
- Dimensional inspection report
- Weld QC and Each Chassis CMM report
- Fixture reference images
- Material test certificates
- Semi tooled up build record

Note: Previous experience in delivering similar work is a must.



Diagram/images of Products:

Next Page
|

JAL

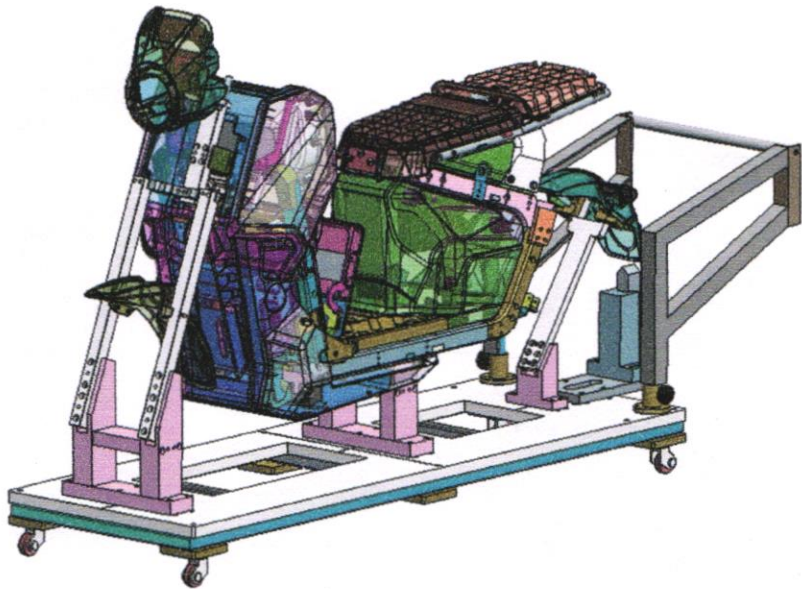
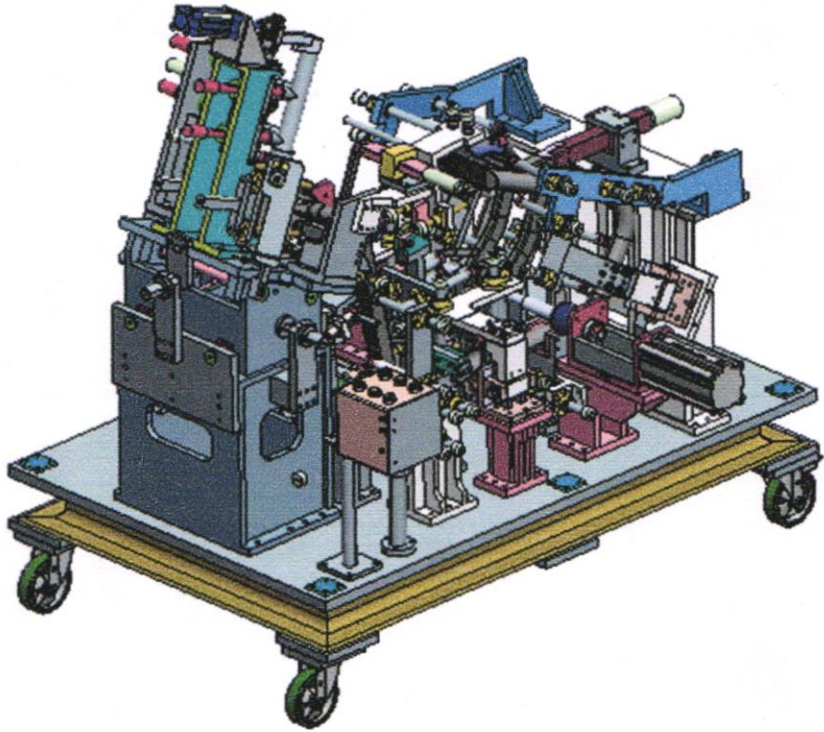

Joe

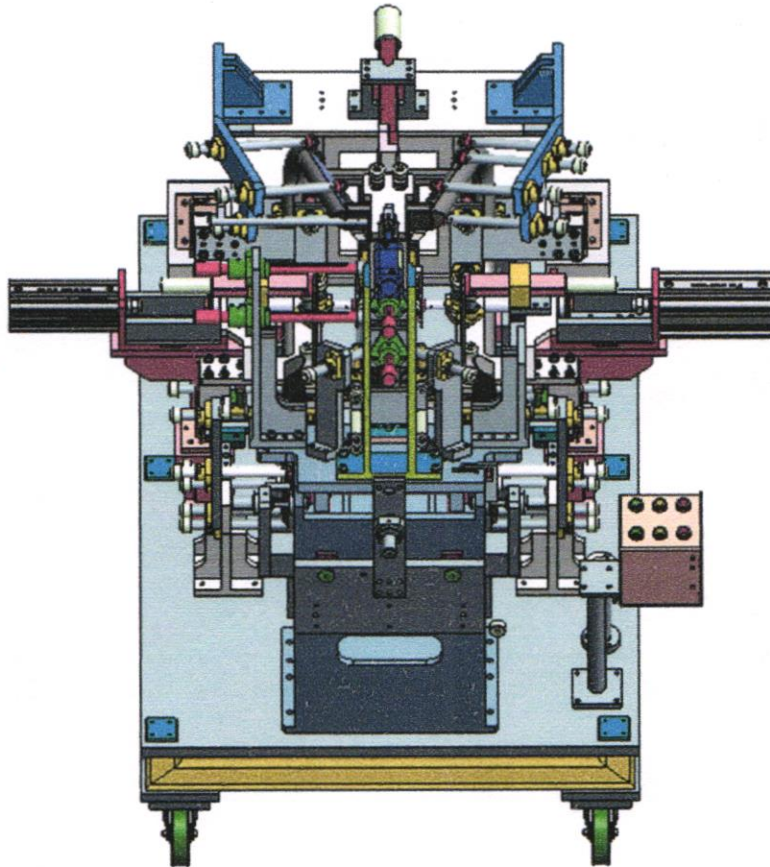
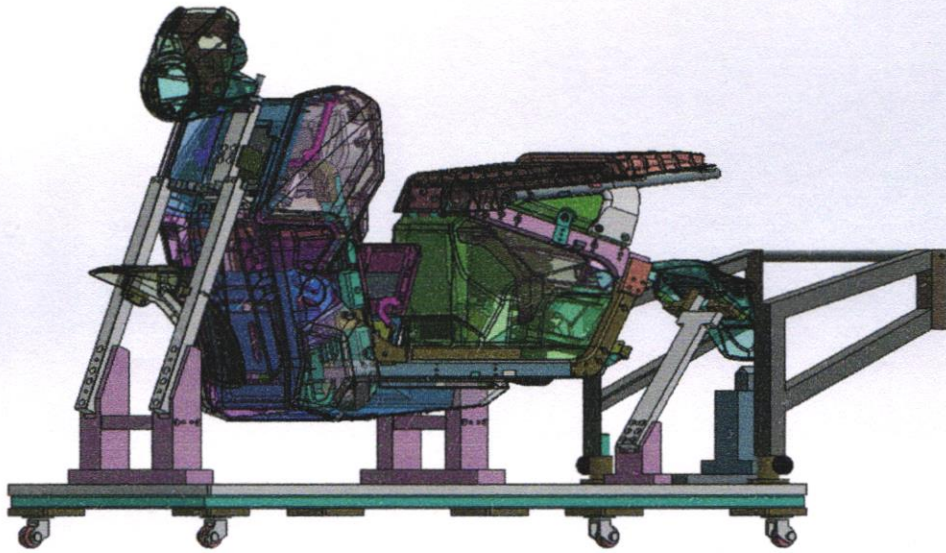

Joe